



MAC Series Condensing Units

H-IM-67H

March 2018

Part #25006401

Replaces H-IM-67H (01/18)

Installation and Operation Manual

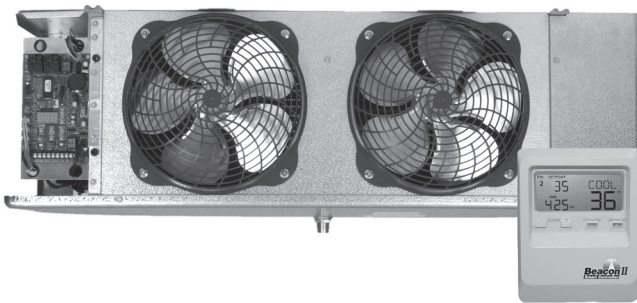

BOHN

TABLE of CONTENTS

General safety and inspection	
Condensing unit specifications	2
Evaporator unit specifications.....	3
Evaporator placement	4
Condensing Unit placement.....	5
Refrigerant piping and line sizes.....	6-8
Leak detection and evacuation.....	9
Field wiring.....	10
Beacon II Controller	
Installation.....	11
Refrigerant line brazing	
Power supply	
Wiring	12
Box temp control settings	
Refrigerant charging	
Start-up operation.....	13
Initial power on	
Operating mode display	14
Program & review settings/changes.....	15-18
Low ambient operation	
Pumpdown	19-20
Defrost.....	20
Alarms and error indicator LED	21
Evaporator fans shut down by operators	
Power failure	
Space sensor terminal	
Checking sensors	22
System defaults	
Control sensor and piping	23
Checking operation of exp. valve	
Exp. valve motor winding resistance	24
Smart Controller.....	25-36
Operational checkout	37
Preventive maintenance	38-40
Diagnostics.....	41-44
Beacon II parts lists.....	45-46
Startup Checklist.....	47-48
Wiring diagrams.....	49-51
Warranty information.....	52

General Safety Information

General Safety Information

1. Installation and maintenance to be performed only by certified personnel who are familiar with this type of equipment.
2. Make sure that all field wiring conforms to the requirements of the equipment and all applicable national and local codes.
3. Avoid contact with sharp edges and coil surfaces, they are a potential injury hazard.
4. Make sure all power sources are disconnected before any service work is done on units.

WARNING: Refrigerant can be harmful if it is inhaled. Refrigerant must be used and recovered responsibly. Failure to follow this warning may result in personal injury or death.

Inspection

Responsibility should be assigned to a dependable individual at the job site to receive material. Each shipment should be carefully checked against the bill of lading. The shipping receipt should not be signed until all items listed on the bill of lading have been accounted for. Check carefully for concealed damage. Any shortage or damages should be reported to the delivering

carrier. Damaged material becomes the delivering carrier's responsibility and should not be returned to the manufacturer unless prior approval is given to do so. When uncrating, care should be taken to prevent damage. Heavy equipment should be left on its shipping base until it has been moved to the final location.

Condensing Unit Specifications

Figure 1.

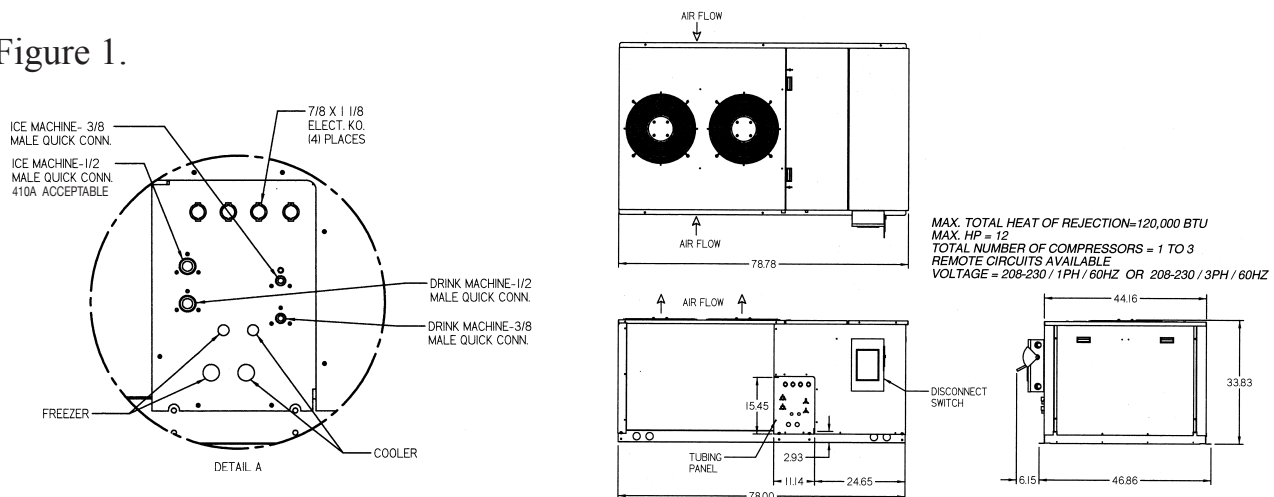

Table 1. Condensing Unit Specifications for R-448A/R-449A

Model	Location	Compressor	Voltage	HP	Unit MCA	Unit MOP	Unit kW	Receiver 90% full lbs.
MAC7X	Freezer	ZF13K4E	208-230/3/60	3	29.2	40.0	6.4	22.0
	Cooler	ZS13KAE	208-230/1/60	1 1/2				9.0
MAC8X	Freezer	ZF15K4E	208-230/3/60	3 1/2	35.6	50.0	6.5	22.0
	Cooler	ZS13KAE	208-230/1/60	1 1/2				9.0

MCA = Minimum Circuit Ampacity MOP = Maximum Overcurrent Protection

Note: Remote circuits internal volume = .10 cu. ft.

Approximate unit weight = 825 lbs.

Evaporator Unit Specifications

Table 2. Evaporator Unit Specifications

MAC7X	ADT104BEB2N6MK	Cooler	10,400	2	45.5	33.25	7/8	1/2	1.0	—	49
	LET120BEB2N6MK	Freezer	12,000	3	61.5	49.25	7/8	1/2	1.5	11.7	60
	LET160BEB2N6MK	Freezer	16,000	4	77.5	65.25	1-1/8	1/2	2.0	15.7	81
MAC8X	ADT104BEB2N6MK	Cooler	10,400	2	45.5	33.25	7/8	1/2	1.0	—	49
	LET160BEB2N6MK	Freezer	16,000	4	77.5	65.25	1-1/8	1/2	2.0	15.7	81
	LET180BEB2N6MK	Freezer	18,000	4	77.5	65.25	1-1/8	1/2	2.0	15.7	84

Figure 2.

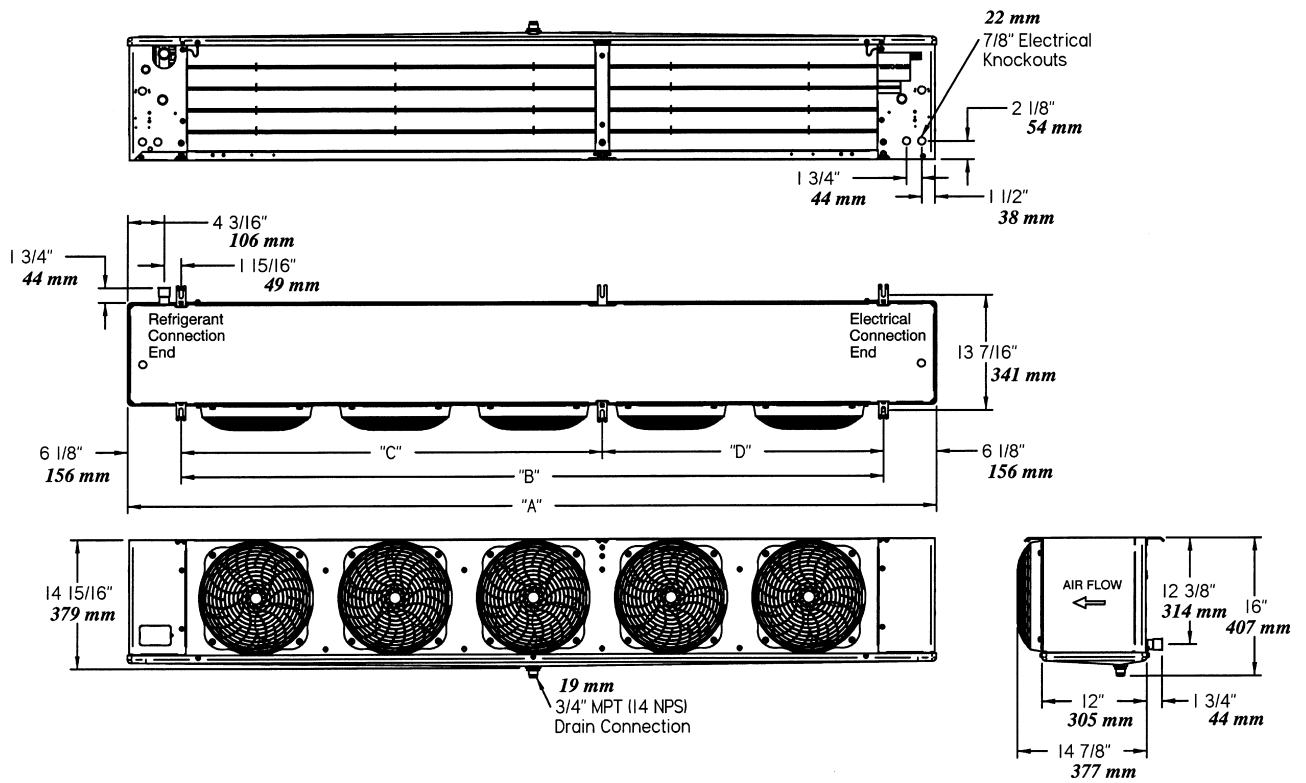

Evaporator Placement

Figure 3. Evaporator Placement In Cooler/Freezer

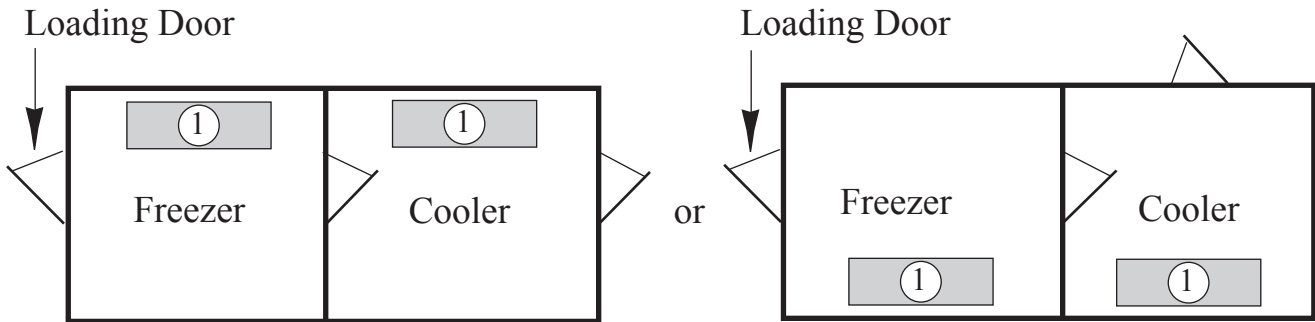

Note: Whenever possible always try to position the evaporator to blow towards the walk-in door. Never position the evaporator over or adjacent to a door opening.

Evaporator Minimum Unit Clearance

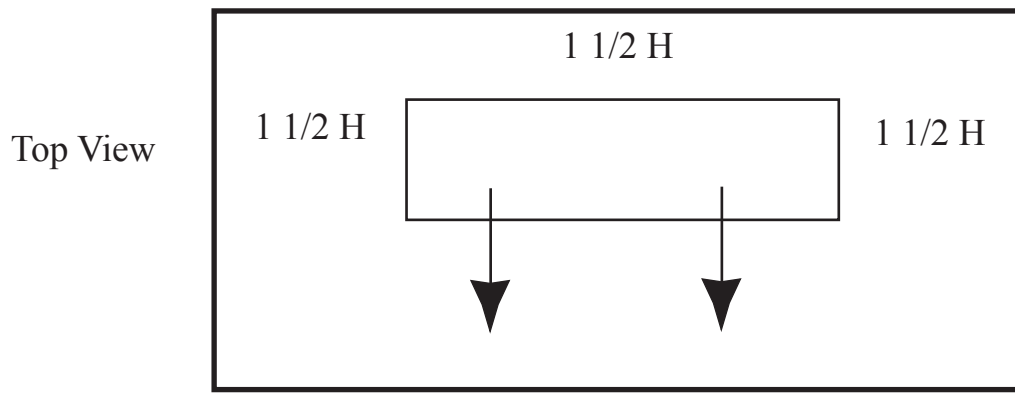

H = Total Height of Unit's Coil Surface

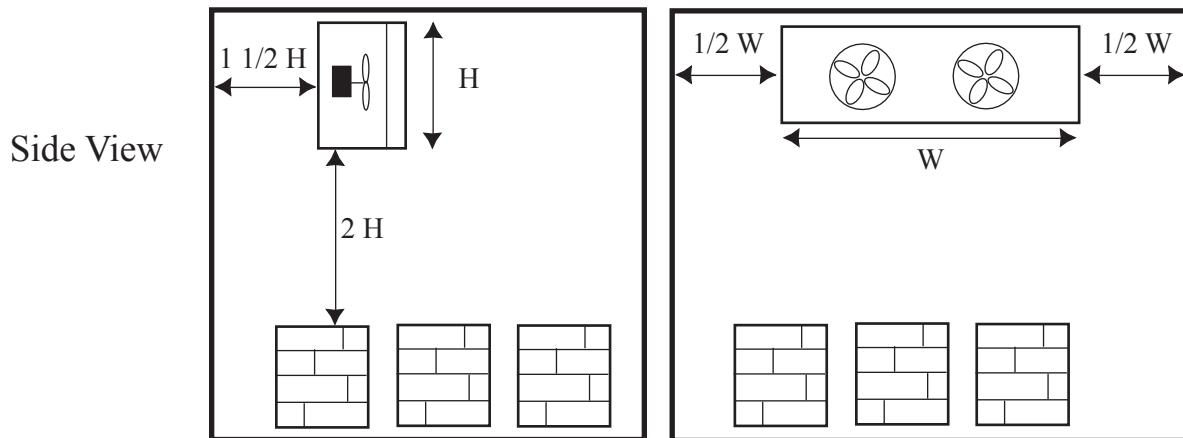

Condensing Unit Placement

Space and Location Requirements

The most important consideration which must be taken into account when deciding upon the location of air-cooled equipment is the provision for a supply of ambient air to the condenser, and removal of heated air from the condensing unit or remote condenser area. Where this essential requirement is not adhered to, it will result in higher head pressures, which cause poor operation and potential failure of equipment. Units must not be located in the vicinity of steam, hot air or fume exhausts. Corrosive atmospheres require custom designed condensers.

unit should be mounted away from noise sensitive spaces and must have adequate support to avoid vibration and noise transmission into the building. Units should be mounted over corridors, utility areas, rest rooms and other auxiliary areas where high levels of sound are not an important factor. Sound and structural consultants should be retained for recommendations.

(Refer to actual building plans for unit locations.)

Another consideration which must be taken is that the

Figure 4.

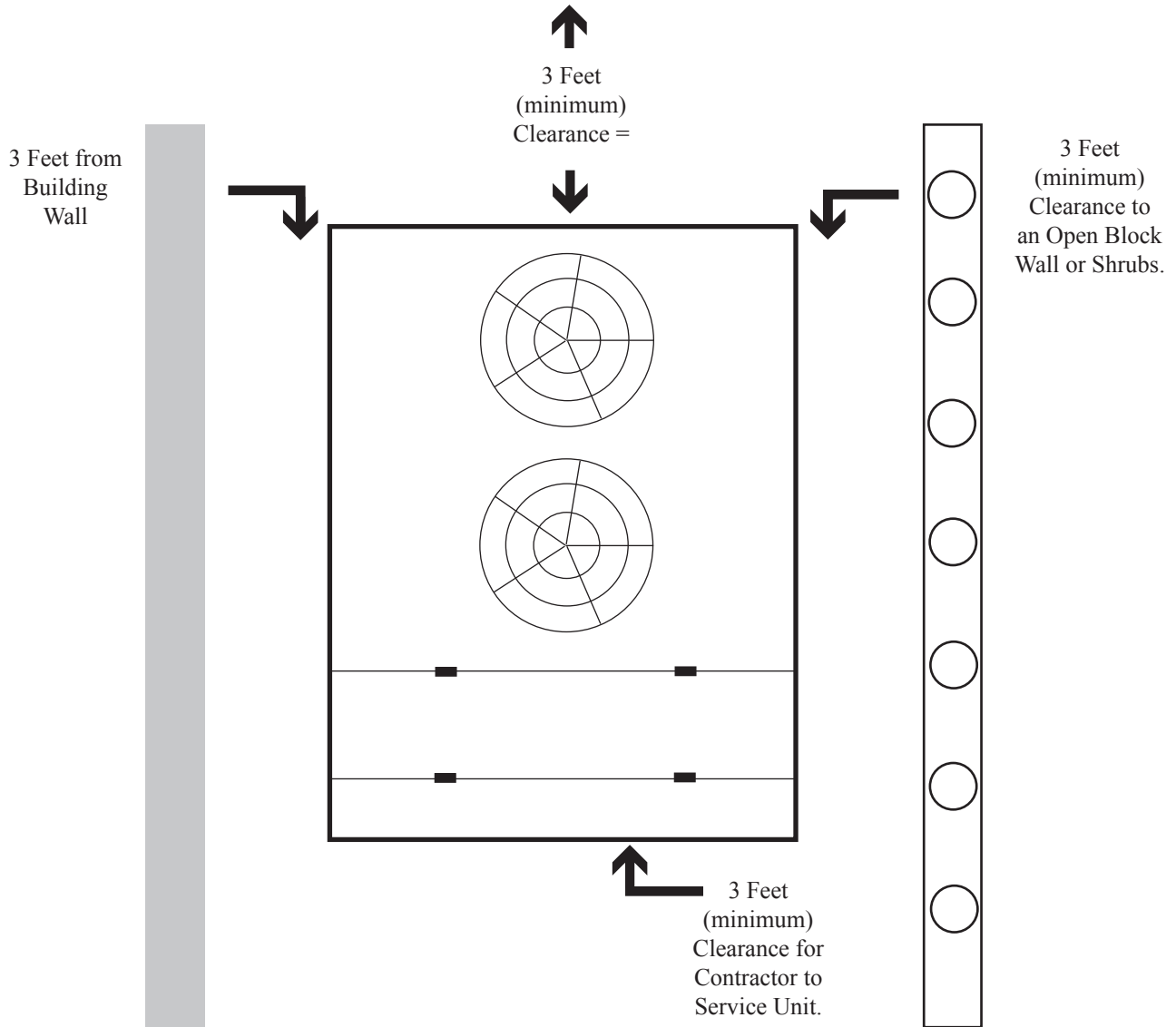

Refrigeration Piping And Line Sizing

Refrigeration Piping And Line Sizing

The system as supplied by Bohn/Heatcraft, was thoroughly cleaned and dehydrated at the factory. Foreign matter may enter the system by way of the evaporator to condensing unit piping. Therefore, care must be used during installation of the piping to prevent entrance of foreign matter. Install all refrigeration system components in accordance with applicable local and

national codes and in conformance with good practice required for the proper operation of the system. The interconnecting pipe size is not necessarily the same size as the stub-out on the condensing unit or the evaporator.

The following procedures should be followed:

- (a) Do not leave dehydrated compressors or filter-driers on condensing units open to the atmosphere any longer than is absolutely necessary.
- (b) Use only refrigeration grade (ACR) copper tubing, properly sealed against contamination.
- (c) Suction lines should slope 1/4" per 10 feet towards the compressor (in direction of flow).
- (d) Suitable P-type oil traps should be located at the base of each suction riser to enhance oil return to the compressor.
- (e) For desired method of superheat measurement, a pressure tap should be installed in each evaporator suction line in the proximity of the expansion valve bulb.
- (f) When brazing refrigerant lines, an inert gas should be passed through the line at low pressure to prevent scaling and oxidation inside the tubing. Dry nitrogen is preferred.
- (g) Use only a suitable silver solder alloy on suction and liquid lines.
- (h) Limit the soldering paste of flux to the minimum required to prevent contamination of the solder joint internally. Flux only the male portion of the connection, never the female. After brazing, remove excess flux.
- (i) Remove temperature sensor attached to suction line on Beacon II systems before brazing of the solder joint internally. Flux only the male portion of the connection – never the female. After brazing, remove excess flux.
- (j) Wrap expansion valves with wet rags during brazing to the liquid line.
- (k) Do not use "bull head" tees. This will cause oil return problems and can cause poor performance.
- (l) If isolation valves are installed at the evaporator, full port ball valves should be used.

CAUTION: If the temperature gets too high, these components may be damaged. Heat absorbing compounds or wet rags must be used to protect the expansion valve when brazing to the refrigerant piping/line connections, and the suction line sensor must be removed per above instructions.

Table 3. Recommended Line Size In Equivalent Lengths for R-448A/R-449A

Model	Room	Max. Riser	Max. Suction Line			Liquid Line		
			25'	50'	Plus 50'	25'	50'	Plus 50'
MAC7X	Freezer	5/8"	5/8"	7/8"	Consult Factory	3/8"	3/8"	Consult Factory
	Cooler	5/8"	5/8"	7/8"	Consult Factory	3/8"	3/8"	Consult Factory
MAC8X	Freezer	5/8"	5/8"	7/8"	Consult Factory	3/8"	3/8"	Consult Factory
	Cooler	5/8"	7/8"	7/8"	Consult Factory	3/8"	3/8"	Consult Factory

Remote Precharged Circuits

The remote precharged circuits are provided with a factory holding charge of R-404A on the soda chiller, and dry nitrogen on the ice machine. The system charge is located in the appropriate drink and ice machines. Schrader valve fittings

are provided for liquid line charging at the condensing unit. Consult the appropriate drink and ice machine manufacturers for details on installation of precharged lines.

Refrigeration Piping

Suction Lines

Note: If the suction line must rise to the point higher than the suction connection on the evaporator, a suction line trap at the outlet of the evaporator must be provided.

Horizontal suction lines should slope away from the evaporator toward the compressor at the rate of 1/4" per 10 feet for good oil return.

Suction lines that are outside of refrigerated space must be insulated. See "Line Insulation" for more information.

Suction Line Risers

Note: To provide proper oil return, a suction trap must be provided at the base of all suction risers.

Prefabricated wrought copper traps are available, or a trap can be made by using two street ells and one regular ell. The suction trap must be the same size as the suction line. For long vertical risers, additional traps may be necessary. Generally, one trap is recommended for each length of pipe (approximately 20 feet) to insure proper oil movement. See Figure 5 below for methods of constructing proper suction line P-traps.

Figure 5. Suction P-traps

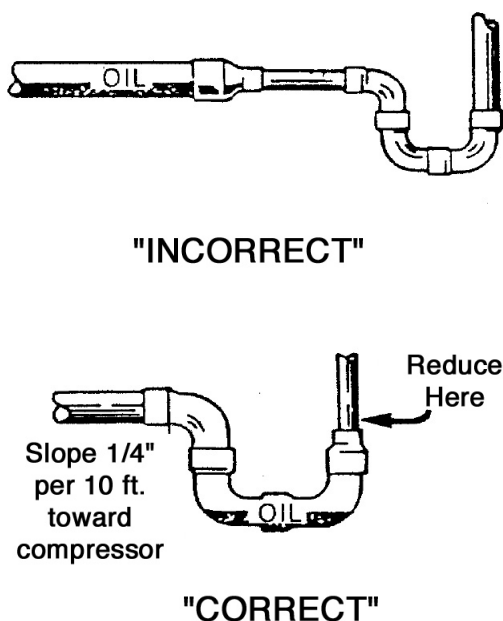

Condensate Drain Lines

Copper drain lines should be used and properly protected from freezing. In running drain lines, provide a minimum of 1/4 inch per foot pitch for proper drainage. Drain lines should be at least as large as the evaporator drain connection. All plumbing connections should be made in accordance with local plumbing codes. All condensate drain lines must be trapped, and run to an open drain. They must never be connected directly to the sewer systems. Traps in the drain line must be located in a warm ambient. See Figure 6. We recommend a trap on all evaporators. Traps located outside, or extensive outside runs of drain line must be wrapped with a drain line heater. The heater should be connected so that it is continuously on. The drain line must be insulated to prevent heat loss. A heat input of 20 watts per lineal foot of drain line for 0°F (-18°C) room applications and 30 watts per lineal foot for -20°F (-29°C) rooms is satisfactory. Inspect the drain pan periodically to insure free drainage of condensate. If the drain pan contains standing water, check for proper installation. The drain pan should be cleaned regularly with warm soapy water.

WARNING: All power must be disconnected before cleaning. The drain pan also serves as cover for hazardous moving parts. Operation of unit without drain pan constitutes a hazard.

Figure 6. Drain Line

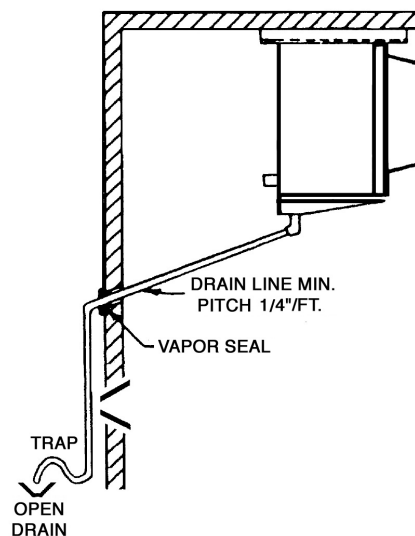

Note: Always trap drain lines individually to prevent vapor migration.

Refrigeration Piping

Figure 7. Example of Pipe Support

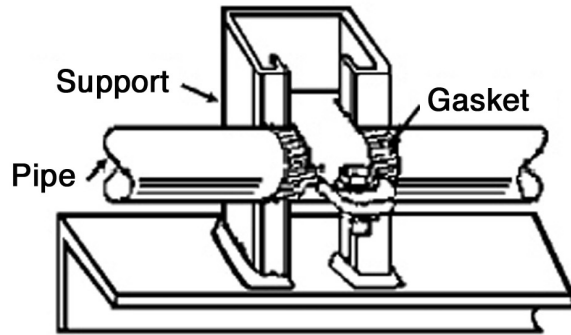

1. See Figure 7.
2. When changing directions in a run of tubing, no corner should be left unsupported. Supports should be placed a maximum of 2 feet in each direction from the corner.
3. Piping attached to a vibrating object (such as a compressor or compressor base) must be supported in such a manner that will not restrict the movement of the vibrating object. Rigid mounting will fatigue the copper tubing.
4. Do not use short radius ells. Short radius elbows have points of excessive stress concentration and are subject to breakage at these points.
5. Thoroughly inspect all piping after the equipment is in operation and add supports wherever line vibration is significantly greater than most of the other piping. Extra supports are relatively inexpensive as compared to refrigerant loss.

Line Insulation

After the final leak test, refrigerant lines exposed to high or low ambient conditions should be insulated to reduce heat loss or gain and prevent the formation of flash gas in the liquid lines. Suction lines must be insulated with 3/4" wall Armstrong "Armaflex" or equivalent. Liquid lines

must be insulated with 1/2-inch wall insulation or better. The insulation located in outdoor environments should be protected from UV exposure to prevent deterioration of insulating value.

Leak Detection And Evacuation

Leak Detection

After all lines are connected, the entire system must be leak tested. The complete system should be pressurized to not more than 150 psig with refrigerant and dry nitrogen. The use of an electronic type of leak detector is highly recommended because of its greater sensitivity to small leaks. As a further check, it is recommended that this pressure be held for a minimum of 12 hours and then rechecked. For a satisfactory installation, the system must be leak tight.

Within the last several years, manufacturers have developed fluorescent dye leak detection systems for use with refrigerants. These dyes mix with the lubricant and, when exposed to an ultraviolet light “fluoresce,” indicate the location of leaks. Copeland has tested and approved the Rigid “System Safe” dye and found it to be compatible with the compressor materials in systems.

A shut-off valve between the gauge connection and vacuum pump should be provided to allow the system pressure to be checked after evacuation. Do not turn off vacuum pump when connected to an evacuated system before closing shut-off valve.

The vacuum pump should be operated until a pressure of 1,500 microns absolute pressure is reached – at which time the vacuum should be broken with the refrigerant to be used in the system through a drier until the system pressure rises above “0” psig.

Note: Refrigerant used during evacuation can not be vented. Reclaim all used refrigerant. EPA regulations are constantly being updated. Ensure your procedures follow correct regulations.

Evacuation

CAUTION: Do not use the refrigeration compressor to evacuate the system. Do not start the compressor while it is in a vacuum.

It is of the utmost importance that proper system evacuation and leak detection procedures be employed. Copeland recommends a minimum evacuation to 500 microns. In addition, a vacuum decay test is strongly recommended to assure there is not a large pressure differential between the system and vacuum pump. Good evacuation processes include frequent vacuum pump oil changes and large diameter, short hose connections to both high and low sides of the system preferably using bronze braided hose.

A good, deep vacuum pump should be connected to both the low and high side evacuation valves with copper tube or high vacuum hoses (1/4” ID minimum). If the compressor has service valves, they should remain closed. A deep vacuum gauge capable of registering pressure in microns should be attached to the system for pressure readings.

Repeat this operation a second time.

Open the compressor’s service valves and evacuate the entire system to 500 microns absolute pressure.

Raise the pressure to 2 psig with the refrigerant and remove the vacuum pump.

Field Wiring

WARNING: All wiring must be done in accordance with applicable codes and local ordinances.

The field wiring should enter the areas as provided on the unit. The wiring diagram for each unit is located on the inside of the electrical panel door. All field wiring should be done in a professional manner and in accordance with all governing codes. Before operating the unit, double check all wiring connections, including the factory terminals. Factory connections can vibrate loose during shipment.

1. The nameplate on the unit is marked with the electrical

characteristic for wiring the unit.

2. Consult the wiring diagram in the unit cooler and in the condensing unit for proper connections.
3. Wire type should be of copper conductor only and of the proper size to handle the connected load.
4. The unit must be grounded.

Figure 9. Beacon II Board

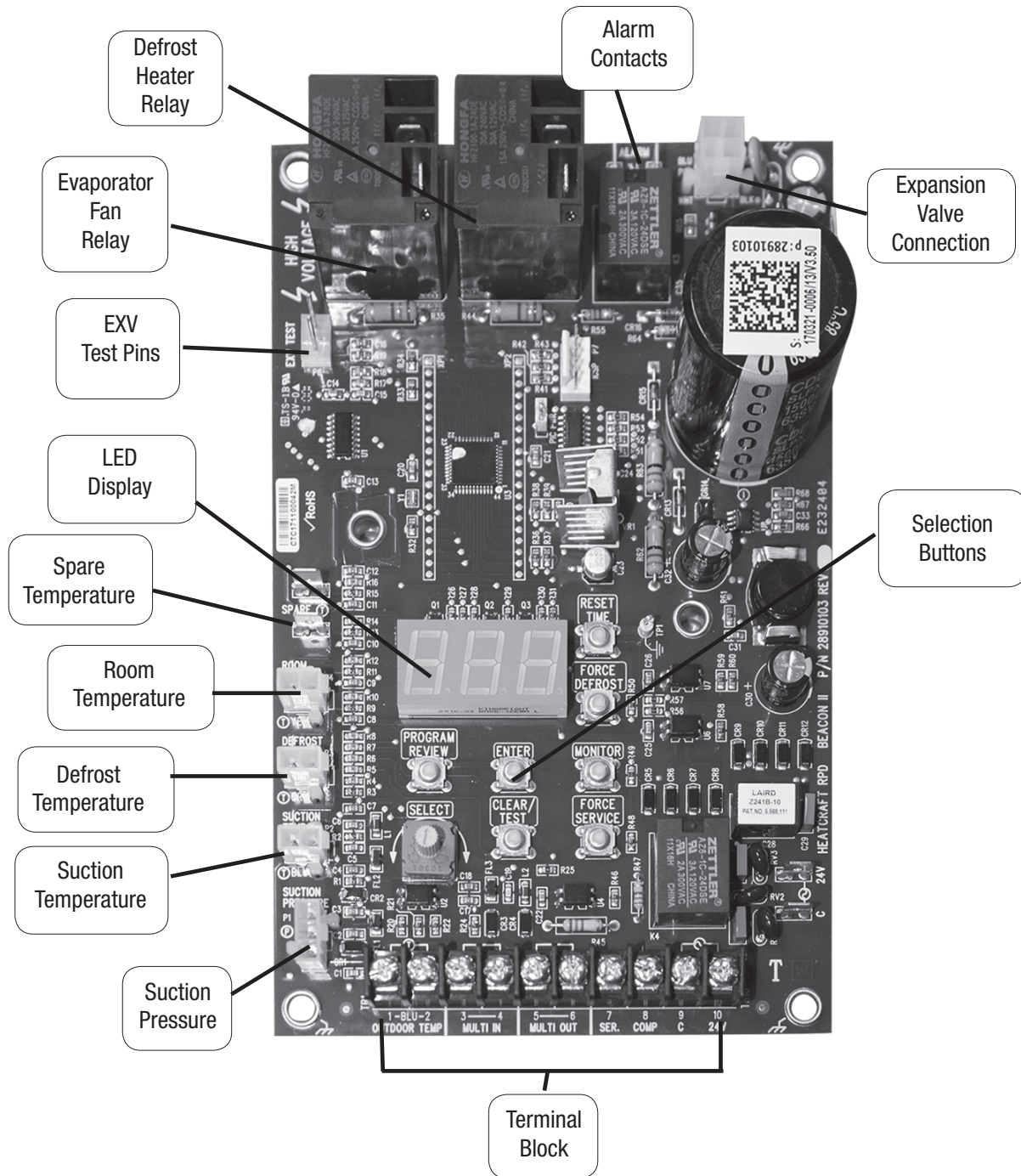

Beacon II Controller

Installation Tips

- Use a minimum 18 gauge wire for all low voltage connections.
- The Beacon II board get its 24 VAC power supply from a transformer mounted in the electrical end of each evaporator. On 208-230 volt systems the multi-tap transformer is shipped from our factory wired for 230 volts. If your supply voltage is 208 volt you must change to the 208 volt tap on the transformer.
 - Refer to wiring schematic shipped on units for wiring.
 - Evaporators are shipped from our factory with a preset box setpoint temperature of 35°F for air defrost and -10°F for electric defrost. If your box setpoint temperature requirements are different this must be set using directions outlined under “Room Temperature Control”.
 - The suction line temperature sensor **MUST** be removed from the suction line before brazing the suction tubing. The sensor **MUST** then be reinstalled on the suction line after brazing is completed and the tubing has cooled. Insulate when finished.
 - The low pressure switch time delay relay, located in the condensing unit, must be set to 1 minute.
 - Some systems may require the crankcase heater to be energized 24 hours prior to start-up. The Beacon II should be de-energized for this period by placing it in the SERVICE MODE. This is done by pressing the “FORCE SERVICE” button twice. To start the system cooling, press the “CLEAR” button.
 - Room sensors must be left connected on ALL evaporators.
 - A pressure transducer is installed on the evaporator. Do not leak test system above 150 PSI or damage to transducer could occur.
 - Refer to the Beacon II Smart Controller Installation Manual, shipped with the Beacon II Smart Controller, for installation, programming and monitoring information.

Condensing Unit

The condensing unit control panel contains the relays, contactors, and a terminal block which is appropriately marked to match the low voltage wiring connections. A sensor for outdoor air temperature measurement is installed on the condensing unit.

Condensing unit must be installed using proper refrigeration practices and codes. Make sure there is good airflow and good clearances around unit. See Figure 4, page 5.

Evaporator Unit

The evaporator contains the BEACON II controller(s), electric expansion valve(s), pressure transducer, distributor(s), orifice(s), transformer and three sensors. These components are all factory mounted and wired. The three sensors are factory mounted and provide input to the controller from the following: defrost temp., suction temp., room temp.

Each evaporator unit must be installed using proper refrigeration practices and codes. Make sure the piping is correctly sized and properly routed. Liquid and suction lines **MUST** be insulated. There must also be good clearance around the unit. See Figure 3, page 4.

Beacon II Controller

Refrigerant Line Brazing (CAUTION)

The electric expansion valve and the suction temperature sensor on the suction line are factory installed. Care must be taken when brazing these lines at the evaporator.

Too high a temperature may destroy these components. Heat absorbing compounds or “wet rags” must be used when brazing the refrigerant line connections. The suction line sensor should be removed before brazing.

Power Supply

The Beacon II board gets its 24 VAC power supply from a transformer mounted in the electrical end of each evaporator. On 208-230 volt systems, the multi-tap transformer is shipped from our factory wired for 230 volts. If your supply voltage is 208 volt, you must change to the 208 volt tap on the transformer.

VERY IMPORTANT: If the supply voltage to the evaporator is 208 volts, the primary tap of the transformer must be moved to the 208 volt tap.

This must be done for all the evaporators on that system.

If the 24 VAC power supply falls below 18 VAC, the system may power down and shut off. When the power supply is corrected to 24 VAC, the system will restart after the four minute hold-off period and resume normal operation.

Wiring

Wiring between the condensing unit and the unit cooler(s) will be as follows (see attached wiring diagrams):

- High voltage – There may be high voltage on the defrost heater relay and the fan relay. See unit cooler spec. plate for ampacity.
- Low voltage – 24V Class II control circuit. A total of five low voltage leads are required to connect the condensing unit to the evaporator (see wiring diagram). Two of these leads are for connecting the outdoor temperature sensor. The other three leads are for connecting the compressor relay, service relay and 24V Common inputs.

All 24 volt wiring must be run separate from the line voltage wiring.

- Number of wires in low voltage wiring bundles:

MAC to cooler evaporator - 5
MAC to freezer evaporator - 5

Cooler evaporator to Smart Controller - 6
Freezer evaporator to Smart Controller - 4

- Low voltage wiring must be 18 gauge minimum. For low voltage wiring, maximum distances are:

Condensing unit to evaporator 500 ft.
Smart Controller to evaporator 1,000 ft.

- Alarm circuit – The onboard alarm (120VAC/2A) is a dry set of NC contacts which closes to indicate an alarm. The type and wiring for the alarm is customer specified. Note that the alarm circuit does not distinguish or indicate what has caused the alarm.
- All wiring must comply with all applicable codes and ordinances.

Note: All four corner brass spacers on the Beacon II board should have sheet metal screws and they all should be screwed in. By doing this, the board will have a ground reference. Make sure the evaporator is grounded.

Beacon II Controller

Box Temperature Control Settings

- There is an on board room thermostat on the Beacon II board which can be adjusted to the desired room temperature. The temperature differential is 2°F.

Temperature Differential

When a system is in the cooling mode and the box setpoint is 35°F, the system will continue to cool until the box temperature gets to 34°F. At this point the compressor will pumpdown and shut off. The system will restart cooling when the box temperature has risen to 36°F.

It is important to note that Beacon II has a minimum 2-minute “ON” time and a

minimum 4-minute “OFF” time. This means that the system will run in the cooling mode a minimum of 2 minutes even if the setpoint temperature is met. In applications where the system is grossly oversized, the box temperature could go below the differential temperature before the system cycles off.

In the “OFF” cycle, the system will be off for a minimum of 4 minutes even if the box temperature goes above the differential temperature before cooling will be restarted.

- The on board room thermostat is factory set at 35°F for air defrost systems and -10°F for electric defrost systems.

Refrigerant Charging

The cooler and freezer systems utilize refrigerant side head pressure control. Charge each system by adding an initial charge of 5 lbs. of R-448A refrigerant to the liquid side of the receiver. This initial charge will allow the system to start. With the system running, continue to add refrigerant to the system until the sight glass is clear.

Operate system until the cooler/freezer box achieves the desired temperature. The sight glass should be clear with no bubbles or flashing of refrigerant. Now the additional charge for the flooded condenser is to be weighed into each system in the amount as shown in Table 4.

Table 4.

Ambient °F.	MAC7X		MAC8X	
	Freezer ZF13	Cooler ZS13	Freezer ZF15	Cooler ZS13
80	3.0	4.0	6.0	4.0
70	2.0	3.0	5.0	3.0
60	1.0	3.0	3.0	3.0
50	1.0	2.0	2.0	2.0
40	1.0	1.0	1.0	1.0
30	0.5	1.0	1.0	1.0
20	0.5	0.5	0.5	0.5
10	0.5	0.5	0.5	0.5
0	0.5	0.5	0.5	0.5

Start-Up Operation

- Check all wiring connections to be sure they are correct and tight.
- On condensing unit:
 - Check the setting of Time Delay relay. It should be set a one minute (the second marker).
 - Check the Low Pressure switch setting on freezer units. It must be set to 0 PSIG cutout, 10 PSIG cut-in to allow positive start and operation, especially in cold ambients. This can be changed to a higher value in warmer climates. On cooler units, the Low Pressure switch has a fixed setting and cannot be adjusted.

Beacon II Controller

Initial Power On

At the initial application of power to the system, the compressor and the evaporator fans will be in a 4 minute hold-off cycle and will not start immediately. When there is a call for COOLING, the expansion valve (EEV) opens, then the compressor is started. The compressor will then run for a minimum of 2 minutes in the “hold-on” cycle. (This means that the compressor will run for a minimum of 2 minutes before shutting off even if the box temperature is met).

The LED alternately displays BOX TEMPERATURE and MODE of operation. On a call for cooling, *dLY* will show while the expansion valve is opening. After the compressor starts, the LED will alternately display BOX TEMPERATURE and *COO*.

When the room thermostat setting is satisfied, and if

the compressor ran for at least 2 minutes, the EEV will close and the compressor will pumpdown and shut off. The evaporator fans will continue to run. The LED will alternately display OFF and BOX TEMPERATURE.

When the room sensor detects a rise in temperature of approximately 2°F, and the compressor has been off for at least 4 minutes, the EEV will open to its last position then the compressor will start. The valve is then adjusted as necessary to obtain the setpoint superheat setting. During this time, the compressor will run for a minimum 2 minutes “hold-on” cycle.

The 4 minute “hold-off” can be bypassed and the system started immediately by pressing the “Reset” button on the Beacon II board.

Figure 10. Operating Mode Display

OFF – Off
COO – Cooling
Pdn – Pumpdown
dEF – Defrost
drn – Draining
dLY – Delay
tSt – Test
SEr – Service



IMPORTANT NOTE:

When a board is installed and power is applied to the system, the following initialization steps should be taken for EACH BOARD in system:

1. Press and Hold the “ENTER” button
2. While continuing to hold the “ENTER” button, press and hold the “CLEAR/TEST” button. “*BBB*” will display on the LED display.
3. Continue to hold both “ENTER” and “CLEAR/TEST” until “*EE?*” displays on the LED.
4. Once “*EE?*” displays, immediately release and the press the “ENTER” again.
5. The board will now re-initialize and return to the normal display.

If “*ncr*” is displayed, then the board did not properly initialize and the steps 1-5 should be re-taken.

Beacon II Controller

Programming And Reviewing Settings/Changes

The Program Review button is used to program, review and change all program settings for the system.

1) Press “PROGRAM REVIEW” button. The Setpoint item will appear on the LED. After a few seconds delay the Setpoint value will display. Each time the button is pressed a different setpoint item is displayed.



2) Next, use the “SELECT” knob to change value of Setpoint Item.

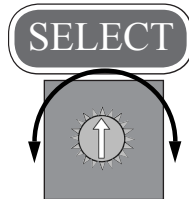

3) Next, when the desired value is selected, press the “ENTER” button to place it in program memory. If the “ENTER” button is not pressed, the value will not be stored in the memory and thus will not be changed.

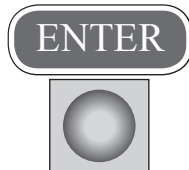

Note: If Smart Controller is in use, do not program the board-- go to pg. 31 to program Smart Controller.

“PROGRAM REVIEW” ITEMS

<i>R-E</i>	- Set Defrost type (Air or ELE)
<i>rEF</i>	- Set Refrigerant type (R-22, R-404A, R-507, R-407A, R-407C, R-407F, R-448A or R-449A)
<i>bot</i>	- Set Box temperature (-30°F to +70°F)
<i>SUP</i>	- Set Superheat (4°F to 20°F)
<i>SLA</i>	- Set Board as a Slave (Yes or No)
<i>ddf</i>	- Demand defrost enable (Yes or No)
<i>dFn</i>	- Set Number of defrosts per day (1, 2, 3, 4, 5, 6, 8, 10 or 12 per day)
<i>dFF</i>	- Set Defrost Fail-safe time (10 to 200 minutes)
<i>dFE</i>	- Set Defrost End temperature (40°F to 100°F)
<i>dFS</i>	- Set Defrost Delay Start Time (0.5 Hours to 23.5 Hours)
<i>RLH</i>	- Set Alarm High temperature (-40°F to 90°F)
<i>RLL</i>	- Set Alarm Low temperature (-40°F to 90°F)
<i>RLt</i>	- Set Alarm time (2 to 120 minutes)
<i>F-C</i>	- Set Fahrenheit / Celsius temperature units (°F/°C)
<i>FnS</i>	- Off cycle fan stir cycle enable (On or OFF)

Beacon II Controller

Programming And Reviewing Settings/Changes (continued)

Use the “PROGRAM REVIEW” button to select these items:



- Defrost Type – “*R-E*” - Selection is made for air defrost or electric defrost coil. This will automatically set the system factory defaults for air defrost and electric defrost. (See default settings.)
- Refrigerant Type - “*REF*” - Selection for type of refrigerant R-22 (22), R-404A (404), R-507 (507), R-407A (47A), R-407C (47C), R-407F (47F), R448A (48A), R449A (49A).
- Box Temperature - “*BOX*” - Select box temperature setpoint. Selection range is -30°F to +70° F. Defaults: Electric defrost -10°F and air defrost +35°F.
- Superheat - “*SUP*” - Evaporator superheat is controlled by the board on each evaporator. Each board measures the evaporator saturation suction temperature and the suction pressure to determine the superheat. The superheat value at the evaporator can be changed to ensure a 20°F to 30°F superheat at the Compressor. Default: 7°F.
- Evaporator Board: Slave? - “*SLR*” - On multiple evaporator systems, each evaporator board has to be programmed to be a Master or a Slave. Each board is shipped from our factory set as a Master. You must make this change to each Slave evaporator. A selection of “YES” is made for this setting.

The default for each board is a Master, so on Single Evaporator systems no change is required.
- Demand Defrost Enable – “*dDF*” – Demand defrost is available for electric defrost systems only. Selection is made to enable demand defrost by a selection of “Yes” or to not enable demand defrost by a selection of “No”. If this parameter is enabled then parameters *dFn* and *dF5* will no longer be displayed in the menu as they are no longer used. Default: electric defrost: No
- Number. of Defrost per Day - “*dFn*” - A selection must be made for the number of defrosts cycles per day – 1,2,3,4,5,6,8,10 or 12 per day. If no selection is made, defaults: electric defrost 4 per day and air defrost 2 per day.
- Defrost fail-safe - “*dFF*” - This is the maximum time allowed for a coil to remain in defrost. Defrost will be terminated if the defrost end temperature is not attained when this time has expired. On multiple evaporator systems, this is controlled by the Master unit. Each board should have the same setting. Defaults: electric defrost 30 minutes and air defrost 40 minutes.
- Defrost End Temperature - “*dFE*” - This is the temperature at which the defrost will be terminated. Defaults: electric defrost +60°F and air Defrost +45°F.
- Defrost Delay Start Time - “*dF5*” - This allows the delay of the start of the first defrost. Default: 0.0 hours.
- Alarm High Temperature - “*ALH*” - Temperature at which a high box temperature alarm will be triggered. This does not apply during defrost. Defaults: electric defrost +5°F and air defrost +50°F.
- Alarm Low Temperature - “*ALL*” - Temperature at which a Low Box Temperature alarm will be triggered. Defaults: Electric Defrost -15°F and Air Defrost +30°F.
- Alarm Time - “*ALT*” - Time which High Temperature or Low Temperature condition must exceed before alarm is triggered. Default: 60 minutes.
- °F/°C - “*F-C*” - Select units to display temperature. Fahrenheit or Celsius. Default: Fahrenheit. When °C is selected, a red dot will appear in the right bottom corner of the LED display of the Heatcraft Quick Response Controller board.
- Off cycle fan stir cycle enable – “*FnS*” – This allows evaporator fan stir cycling in the off cycle utilizing a fixed stir cycle timing of 7 minutes on and 5 minutes off. Selection is made to enable off cycle stir cycling by a selection of “*On*” or to not enable off cycle stir cycling by a selection of “*OFF*”. Defaults: electric defrost off and air defrost off

Beacon II Controller



Use this button to **"FORCE DEFROST"**. To force a defrost, press the **"FORCE DEFROST"** button. The system will pumpdown. The heaters are then turned on. The display will show **"dEF"** and room temp.



Use the "MONITOR" button to review these items:	
<i>SUP</i>	- Superheat (°F/°C)
<i>ESP</i>	- Expansion valve steps (0 to 255 steps)
<i>SLT</i>	- Suction temperature (°F/°C)
<i>SSL</i>	- Saturated Suction temperature (°F/°C)
<i>SCP</i>	- Suction pressure at Evaporator (PSIG/HG)
<i>OdT</i>	- Outdoor temperature (°F/°C)
<i>dFt</i>	- Defrost sensor temperature (°F/°C)
<i>dFS</i>	- Time left until next defrost (hours) (on version 1.8 boards)
<i>dFE</i>	- Last Defrost Elapsed time (minutes)
<i>RC</i>	- Board Voltage
<i>SPt</i>	- Spare Temperature reading
<i>rEL</i>	- Software release program

Use this button to **"RESET TIME"**. Pressing this button will reset the time clock in the microprocessor to zero. At initial power up, pressing this button will bypass the "four minute" hold-off and the system will start immediately after the expansion valve opens. This display will show **"dLY"**.

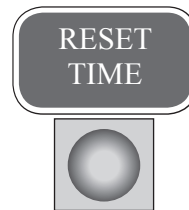

Use this button to **"FORCE SERVICE"**. Pressing this button TWICE will cause the system to pumpdown. The system will remain off until the **"CLEAR"** button is pressed. While in the **"FORCE SERVICE"**, the LED display will only show **"SEr"**.



Beacon II Controller

Programming And Reviewing Settings/Changes (continued)

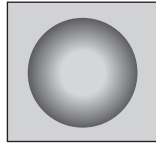

Use this button to “CLEAR/TEST”

Pressing this button ONCE will return the LED display to the default display. With the system in the OFF mode, pressing and holding this button will start the “TEST” mode. In the “TEST” mode it will cycle through each output.

STATUS INDICATOR LED

A red, 3-digit, alphanumeric LED on the Beacon II board indicates status, alarms and error codes.



Status	LED Display	Description
<ul style="list-style-type: none"> • OFF All Evaporators 	Box Temp / OFF	Box Temperature / Mode is displayed
<ul style="list-style-type: none"> • COOLING Single Evaporator 	Box Temp / E00	Box Temperature / Mode is displayed
<ul style="list-style-type: none"> • Pumpdown All Evaporators 	Pdn	
<ul style="list-style-type: none"> • DEFROST All Evaporators 	dEF	
<ul style="list-style-type: none"> • TEST All Evaporators 	tSt	
<ul style="list-style-type: none"> • SERVICE All Evaporators 	SEr	
<ul style="list-style-type: none"> • ALARMS 	A1	High Box Temp
	A2	Low Box Temp
	A3	System has failed to start the compressor on 4 consecutive attempts.
	A4	Input Fault Box Temp., Suction Temp., Pressure Transducer open or not installed

Beacon II Controller

Status Indicator LED (continued)

Status	LED Display	Description
• ERRORS	E1	Room temperature sensor shorted, open or not installed
	E2	Defrost temperature sensor shorted, open or not installed
	E3	Suction temperature sensor shorted, open or not installed
	E4	Suction pressure transducer shorted, open or not installed
	E5	Outdoor temperature sensor shorted
	E6	Low superheat during cooling
	E7	Compressor shutdown (high or low refrigerant pressure or low oil pressure)
	E9	Multi-in/Multi-out wiring error
• OTHERS	Loc	Board is locked. Settings cannot be changed
	UnL	Unlock the board settings

Pumpdown

At the end of each cooling cycle, when the box temperature is met and the minimum hold-on time has been satisfied, the Beacon II system will pump-down and shut off the compressor.

To pumpdown, the EEV closes and the compressor runs until the low pressure switch opens or 2 minutes has elapsed. The compressor is then off and remains off until the start of the next cooling cycle.

While in the off cycle, the system will initiate a short pumpdown at 4-minute intervals, only if the Low Pressure Switch closes, to ensure that any refrigerant leakage will not cause a problem.

For Manual Pumpdown, a single pole, single throw switch can be used to connect "SERVICE" and "Com". This can be done at the Beacon II board on the evaporator or at the terminal board in the condensing unit. This will cause the system to pump down and shut off.

Note: The system will not restart until the switch has been opened. The Beacon II board will display "5Er".

OR

The system can be pumped down by pressing the "SERVICE" button twice. To restart the system, press the "CLEAR" button.

OR

The system can be pumped down for service by closing the liquid line service valve on the receivers in the condensing unit, then closing the suction line service valve when the system trips on the low pressure switch.

Beacon II Controller

Service Mode

A SPST switch (S1 & S2) is supplied, for each system, in the condensing unit for shutting off the system. Closing the “Service” switch in the condensing unit will cause the expansion valve to close and the compressor to pumpdown and shutoff. “SEr” will be the onboard LED display and “SERVIC” is displayed on the Smart Controller. The evaporator and heater relays on the Beacon II board will then be deactivated. The system will not restart until the switch is placed in the “NORMAL” or off position.

When the “Service” switch in the condensing unit is closed or ‘on’ (labeled SERVICE), the system is in the service mode. If the switch is ‘off’ (labeled NORMAL), the system is in normal operation

Defrost

DEFROST TIMING

When power is first applied to the system, its timer starts counting time. If 4 defrosts are programmed, it will initiate a defrost every 6 hours from when power was first applied. Beacon II does not have a real time clock. Beacon II does provide the ability to delay the starting of the first defrost.

DEFROST DELAY START TIME

Example: The system is first powered up at 8:00 AM and is programmed for 4 defrosts per day. The user would like the first defrost at 10:00 AM. To accomplish this, use the “PROGRAM REVIEW” button to scroll to *dF5*. Use the “SELECTOR” switch to select 2 hours delay start, then press “ENTER”. The first defrost will now occur at 10:00 AM and then a defrost will occur every 6 hours thereafter.

TIME REMAINING UNTIL NEXT DEFROST

To find out how much time is left until the next defrost is scheduled, use the “MONITOR” button to scroll to *dF5*. The time displayed will be how much time until the next scheduled defrost.

DEFROST SCHEDULE IN MEMORY

Beacon II does not have a real time clock but it keeps track of the time that has elapsed in its memory. It also keeps in memory the number of defrosts scheduled and how much time has elapsed between defrosts. If a power failure occurs, when power is restored Beacon II will remember how many defrosts are scheduled and it will remember how much time was left until the next defrost. It will then defrost based on this timing. So, if the power failure lasted 15 minutes, the defrost schedule will be off by 15 minutes.

ELECTRIC DEFROST MODE

When a defrost is initiated, the EEV closes and the compressor is allowed to pumpdown and shut off. The evaporator fans are cycled off and the defrost heaters are energized.

There is a 2-minute condensate drain-down period after which the compressor is started for a refreeze period. The evaporator fan stays off (fan delay). The refreeze period will last until the evaporator suction temperature is at 28°F or 3 minutes has elapsed. After this sequence, the system is back in the refrigerating mode and the evaporators’ fans are not running.

AIR DEFROST MODE

The sequence is the same as for electric defrost except that there are no heaters and the evaporator fans run continuously.

Beacon II Controller

Alarms

Beacon II provides a set of dry contacts for use in signaling an alarm. These contacts can be connected to a light, a buzzer, a bell, etc., (not to exceed 115 volts and 2 amps) which will be activated when an alarm condition occurs. When the Beacon II is energized, the alarm contacts are OPENED. When an alarm condition is detected, the contacts are CLOSED.

Conditions under which the alarm contacts will close are:

- High Box Temperature – LED Display: $A1$ – Room temperature has exceeded the Alarm High $A1H$ value for the Alarm time $A1t$, programmed.
- Low Box Temperature – LED Display: $A2$ – Room temperature has dropped below the Alarm Low $A2L$

value for the Alarm time $A1t$, programmed.

- System Start-Up Failure – LED Display: $A3$ – Compressor pumps down and tries to restart after four minutes.
- Input Fault – LED Display: $A4$ – Box Temp., Suction Temperature, or Pressure Transducer open or not installed.
- Power Failure – Loss of power to the Evaporator.

ALARM CODES	
$A1$	High Box Temperature
$A2$	Low Box Temperature
$A3$	System Start-Up Failure Indicates that the system has failed to start the compressor on 4 consecutive attempts.
$A4$	Input Fault Box Temperature, Suction Temperature, Pressure Transducer open or not installed

Error Indicator LED

At initial power up, each Beacon II board checks for system errors. The system error check involves checking the various temperature sensors to determine whether any of these sensors are shorted or open.

The system will pumpdown and cycle off and will not restart until the fault is cleared or the circuit breaker reset, for the following conditions:

- E3: Suction sensor shorted, open, or not installed
- E1: Room temperature sensor shorted, open, or not installed
- E4: Pressure transducer shorted, open, or not installed

The system will pumpdown, cycle off and try to restart for these faults. Each try will be after the 4 minutes “Hold Off” period, for the following fault conditions:

- E7: High pressure or low pressure cutout
- E6: Low superheat

After the fourth try, the Alarm contacts will be closed and an alarm message displayed on the LED.

To clear the error for E2 (Defrost Temp Sensor Open/Short) and E5 (Outdoor Temp Sensor Open/Short) the fault must be resolved. However, the system will remain running during E2 and E5.

ERROR CODES	
$E1$	– Room temperature sensor shorted, open or not installed
$E2$	– Defrost temperature sensor shorted, open or not installed
$E3$	– Suction temperature sensor shorted, open or not installed
$E4$	– Suction pressure transducer shorted, open or not installed
$E5$	– Outdoor temperature sensor shorted, open or not installed
$E6$	– Low superheat
$E7$	– Compressor shut down (high or low pressure switch open or oil pressure switch open).
$E9$	– Multi-in / multi-out wiring error

Beacon II Controller

Evaporator Fans Shut Down By Operators

In some installations, it is desirable to shut off the evaporator fans for product loading. This is easily accomplished on Beacon II by wiring a single pole switch (SPST) between the terminals on the Beacon II board marked "SERVICE" and "COM". Closing this switch will cause the system to pumpdown and shut off the compressor and the evaporator fans. The switch must be reopened before the system will restart. This SPST switch and wiring is field supplied and field installed.

Power Failures

In the event of a power failure, Beacon II will automatically close the expansion valve to prevent refrigerant from migrating throughout the system. After power returns, with 24 VAC at the board, the system will restart in the cooling mode after the 4-minute hold off period. The alarm contacts will close triggering any alarm device that is connected.

Spare Sensor Terminals

Beacon II provides a set of input terminals for customers who may want to monitor an additional temperature or items such as Product Temperature. This input terminal requires a signal from a thermistor which meets the temperature/resistance values in Table 5 below.

If a product temperature simulator is used, it must meet the resistance/temperature specification listed in Table 5. The temperature range for this input is -30°F to 140°F.

Sensors on the Beacon II system, as supplied, will not simulate product temperature.

This input can be monitored on the LED display by using the "MONITOR" button and scrolling the SPt . The values displayed will be the temperature of the spare sensor.

Checking Sensors

DO NOT REMOVE SENSORS FROM COIL FOR CHECKING. Use the monitor button to display the value the sensors are reading on the LED (suction temp. SPt , defrost temp. dFt or room temp.). Compare this value to the measured value with a thermometer at each of these points. If they do not match, change the sensor.

The sensors can be checked for their proper operation by placing it in a cup of ice water. Stir the ice water and measure the resistance of the sensor. At 32°F the resistance should be 32,650 ohms. If it is higher or lower by 1,000 ohms approximately, the sensor should be replaced.

Table 5. Resistance / Temperature Specification

Temperature °F	Ohms	Temperature °F	Ohms
104	5,320	32	32,650
86	8,060	23	42,330
77	10,000	14	55,330
68	12,490	5	72,950
59	15,710	-4	97,070
50	19,900	-13	130,410
41	25,400	-22	176,960

Beacon II Controller

System Defaults

Refrigerant	REF TYP	R-404A	R-404A
Box Temperature	BOXTMP	35F	-10F
Superheat	SUPRHT	7F	7F
Smart Defrost	SMTDEF	N/A	On
Demand Defrost	DMDDFT	N/A	Off
Defrost Start Times	DET ST	9am/9pm	3am, 6am, 9am, 12pm, 3pm, 6pm, 9pm, 12pm
Defrost Fail-Safe Times	DEF5AF	40 min.	60 min.
Defrost End Temperature	DEFTMP	45F	55F
Alarm High Temperature	ALR HI	50F	5F
Alarm Low Temperature	ALR LO	30F	-15F
Alarm Time	ALRMIN	60 min.	60 min.
Temperature Units	F-C	F	F
Clock Setting	12/24H	12 H	12H
Fan Cycling	FNSTIR	Off	Off
Test Mode	TEST	Off	Off
Service Mode	SERVIC	Off	Off

Figure 11. Control Sensor And Piping

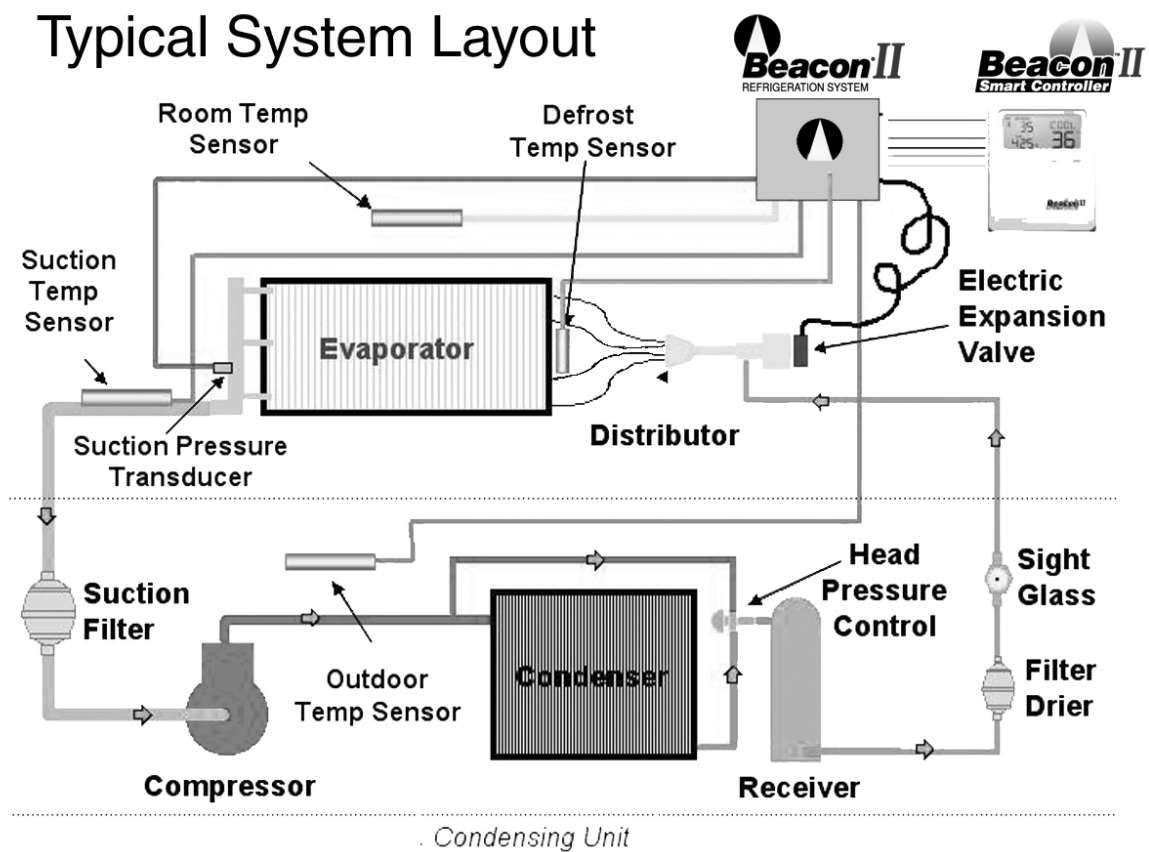

Beacon II Controller

Checking Operation Of Expansion Valve (EEV)

1. To check if the expansion valve is closing properly;

Install a pressure gauge-set to suction line at the condensing unit. With the system running, close the valve on the liquid receiver, at the condensing unit. The system should pumpdown and shut off on the Low Pressure switch (LPS). If the system does not pumpdown and trip on the LPS then the compressor valves are weak and needs to be changed.

After the system pumps-down and trip on the LPS, turn off the power to the Beacon II board, then turn the power back on. This will cause the Expansion valve to close.

Open the valve on the liquid receiver, at the condensing unit. The suction pressure reading on the gauge set should not increase. If the suction pressure increases then the expansion valve is leaking and should be changed.

2. The expansion valve position can be monitored from the LED display pressing the “MONITOR” button and scrolling to $E5P$. This will indicate the number of steps the valve is open.

This can also be checked by using the EXV test pins on the board. This is indicated by a 0 to 5 Volts DC signal. At 0 Volts the valve is closed and at 5 Volts the valve is fully open. At values between 0 and 5 Volts, the valve will be opened proportionately.

3. Use the “MONITOR” button to display “ $E5P$ ” Evaporator Suction Pressure. Record the pressure displayed. Start the system and observe the pressure displayed. If the pressure does not increase, the expansion valve could be defective.

4. If the system is running, use the “MONITOR” button to display “ $E5P$ ” Evaporator Suction Pressure. Record the pressure displayed. While the system is running, press the “FORCE SERVICE” button. Observe the pressure while the system is pumping down. The pressure should decrease. If it does not, this indicates a defective valve.

Expansion Valve Motor Winding Resistance

If the expansion valve is suspected of not functioning properly the motor windings resistance should be measured. This is a bipolar motor with two windings. Measure the resistance at the pins, on top of the valve, between locations A and B or C and D.

(Note that the pins are not labeled A, B, C, D. This labeling is just for reference).

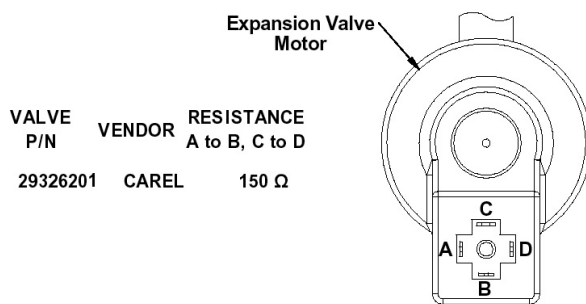

Resistance reading at 150 Ω at 75° F

“C” is largest spade

CAREL VALVE

Measuring resistance between locations A and C or B and D will always show “Open” because these locations are between the motor windings.

When the valve is opening or closing, the voltage measured between A and B or C and D should be between 20 to 22 VAC.

Beacon II Smart Controller

The Smart Controller performs all of the standard Beacon functions with the additional benefit of remote monitoring. The Smart Controller is mounted in the manager's office and the refrigeration system can be monitored and changed without going to the cooler or freezer. The Smart Controller with LCD display will also alert you to any alarm conditions in

your refrigeration system. The Smart Controller will display the problem in addition to letting you know when to call for service. See pages 49-51 for proper wiring instructions. Refer to the installation and operation manual that ships with each Smart Controller for complete instructions.

NOTE: One Smart Controller controls both the cooler and freezer.

Beacon II Smart Controller Features

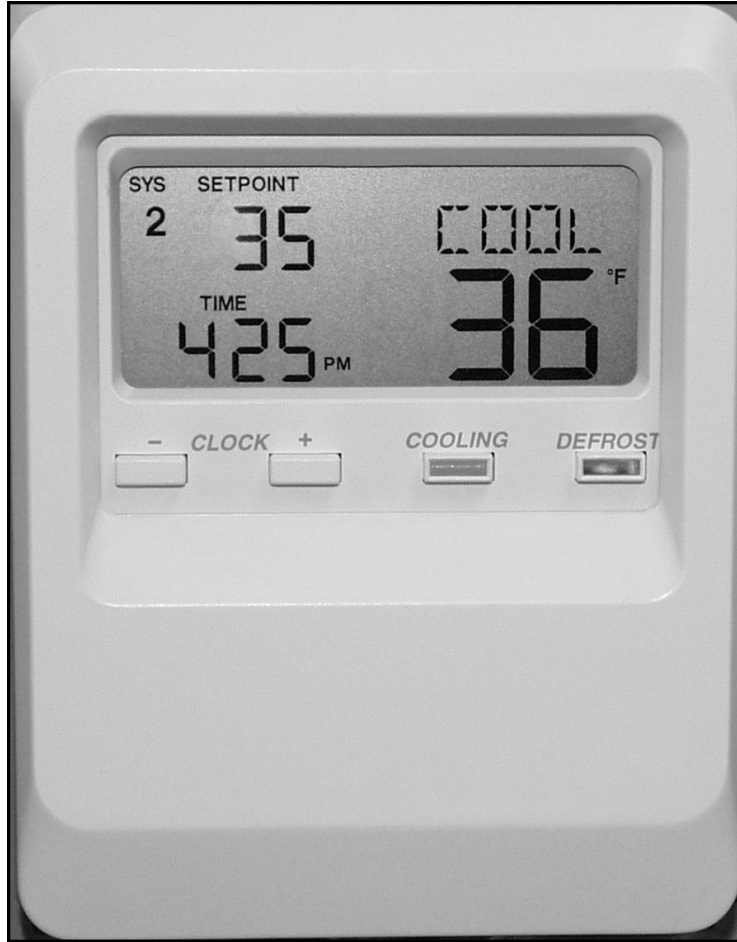

The Beacon II Smart Controller performs all the standard Beacon functions with the additional benefit of:

- a) Remote mounting for easy access
- b) Remote monitoring and programming through integration with Heatcraft RRC (Remote Refrigeration Control). Visit www.heatcrafttrpd.com for more information.
- c) Controlling four completely separate systems
- d) Smart Defrost
- e) Has buzzer to signal alarms
- f) Locking keypad

Beacon II Smart Controller allows complete programming and monitoring of the system. The Controller display has the following buttons: COOLING, DEFROST, PROG REVIEW, MONITOR, ENTER, CLEAR, SETPOINT AND TIME.

The normal LCD display will show the Programmed Box Set-point temperature. Actual Box Temperature, the Current Time of day and the Mode (i.e. COOL, DEFROST or OFF). When multiple systems are being controlled, the system number (i.e. SYS 1, SYS 2, SYS 3, SYS 4) will also be displayed on the LCD.

Beacon II Smart Controller Features

- Monitoring of the complete refrigeration system.
- Programming of a variety of parameters for the optimum control of the refrigeration system.
- The Beacon II Smart Controller has a Liquid Crystal Display (LCD) which shows: current time, actual box temperature, box temperature set-point and if there is an alarm or fault condition..
- Smart Defrost to save energy on defrost.
- Sounds a buzzer to indicate an Alarm condition.
- Can be mounted up to 1000 ft. away from the system being controlled.
- Each Beacon II Smart Controller can control four independent systems with up to 4 evaporators on each system.
- A Backup battery will maintain the clock settings for 10 years.
- Double E PROM Chip will maintain program settings indefinitely.
- Locking feature to prevent unauthorized access to program settings.

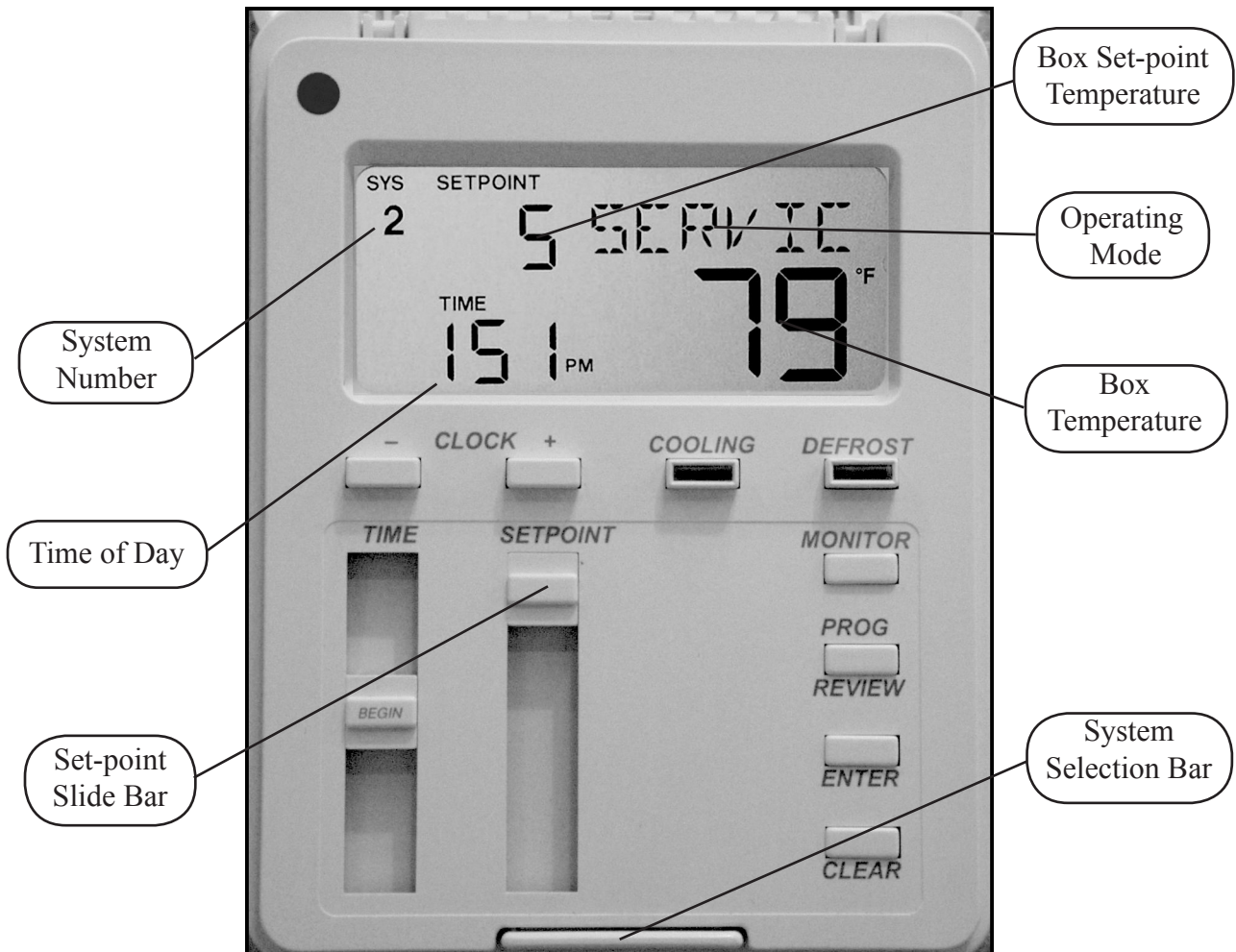

Installation

Installation

The Smart Controller should be installed in a location where the large Liquid Crystal Display (LCD) can be viewed easily, yet is secure and vibration free. Because of the LCD screen, the Smart Controller II should not be mounted where it will experience temperatures below 40 °F or above 100 °F.

A terminal strip for wiring connections is located on the base of the Smart Controller. To access this terminal strip, pull both halves of the Smart Controller housing apart. Mounting holes are located in the plastic base.

Beacon II Smart Controller Base

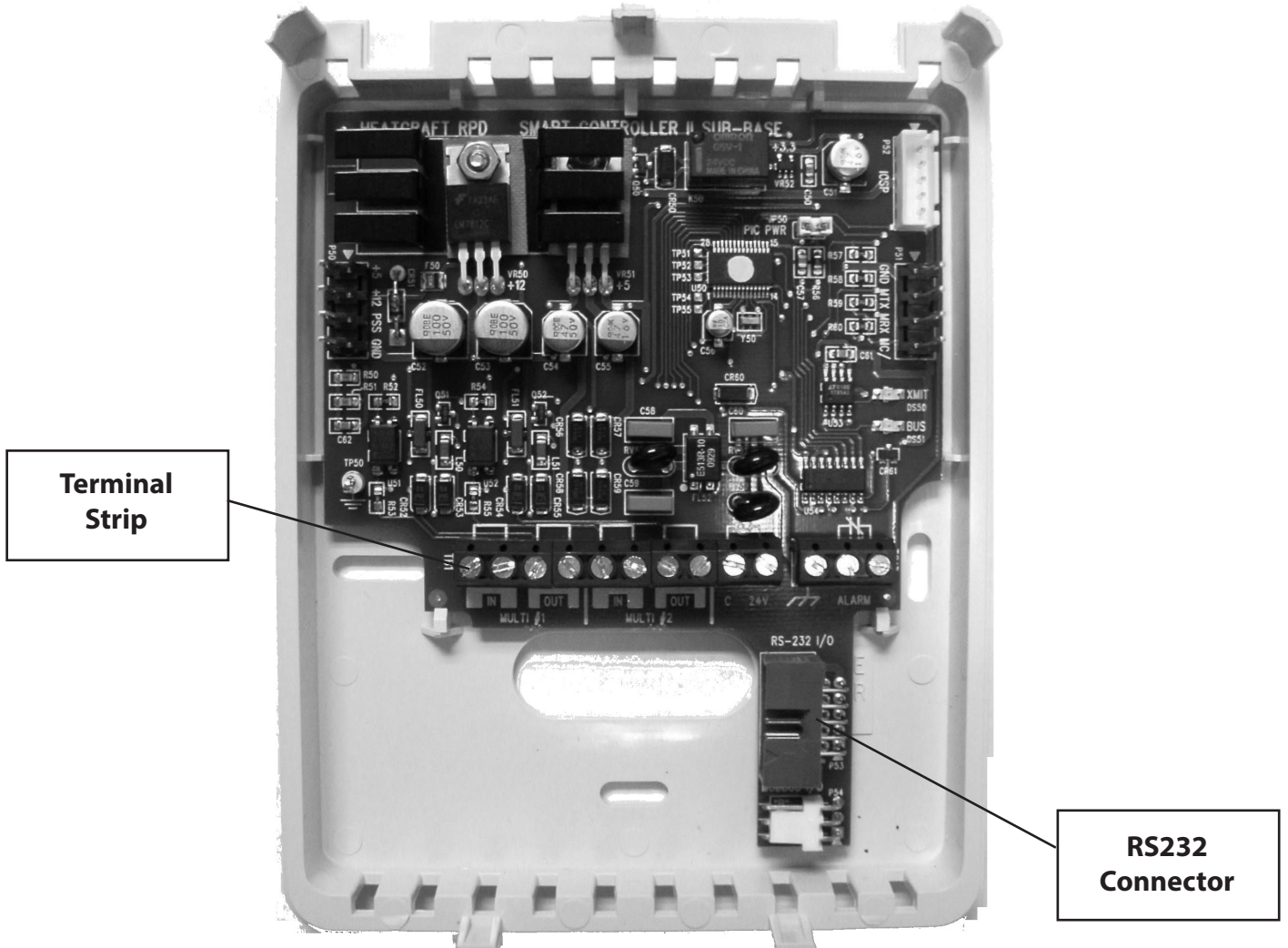

Wiring

Wiring

All 24 volt wiring must be run separate from the line voltage wiring.

The terminal strip in the Smart Controller is labeled similarly to that of the Beacon II boards. Connect the corresponding terminals to those on the Beacon board.

For single Refrigeration system:

Connect MULTI OUT 1 from the Smart Controller to the MULTI IN on the Beacon board on the Evaporator. Then connect MULTI IN 1 from the Smart Controller to the MULTI OUT on the Beacon board on the Evaporator. See typical wiring diagram at the back of these instructions.

For MULTIPLE independent Refrigeration systems:

For the first system, connect MULTI OUT 1 from the Smart Controller to the MULTI IN on the Beacon board on the Evaporator in this first system. Then connect MULTI IN 1 from the Smart Controller to the MULTI OUT on the Beacon board on the Evaporator on this first system. DO NOT disconnect the Room sensor from any of the Evaporators. See typical wiring diagram at the back of these instructions.

A minimum 18 gauge wire should be used. All low voltage wiring must be run separate from high voltage wiring.

Power Supply

The Beacon II Smart Controller gets its 24 VAC power supply from an evaporator. When controlling multiple systems, the Beacon II Smart Controller is powered from the evaporator of only one of the systems. If a power interruption occurs to the system supplying the Smart Controller II, the Smart Controller II LCD screen will go blank. The other systems will, however, continue to operate and maintain their box temperature.

If the Beacon II Smart Controller LCD displays all “BBBBB” this indicates that the power supply is below 18 VAC. When this occurs the system will power down and shut off. When the power supply is corrected to 24 VAC, the system will restart after the four-minute hold off period and resume normal operation. The Beacon II Smart Controller LCD display will then be normal.

Initialization of Beacon II Smart Controller

INITIALIZATION of BEACON II SMART CONTROLLER

When power is first applied to the Beacon II Smart Controller it checks the configuration of the system to which it is connected and stores this in its memory. Beacon II Smart Controller checks how many condensing units there are and how many evaporators are connected to each condensing unit. This is called Initialization.

Whenever a system is added, removed or modified (changing the number of evaporators on a condensing unit), while connected to the Beacon II Smart Controller, Beacon II Smart Controller must be re-initialized.

Make sure all wiring changes to the system and Beacon II Smart Controller are complete before initializing the Beacon II Smart Controller.

INITIALIZATION STEPS

- Put all systems in “SERVICE” using the service switch, before turning on power.
- Press and Hold both the “ENTER” and “CLEAR” buttons on Smart Controller.
- Hold both the “ENTER” and “CLEAR” buttons down until the LCD screen of the Smart Controller displays “EEROM?”
- When “EEROM?” is displayed, release both buttons and press the “ENTER” button within 2 seconds.”
- The Smart Controller LCD screen will display “WAIT.”

After “WAIT” is displayed it may take up to 2 minutes for the initialization to be completed and the normal LCD screen is displayed.

- If unsuccessful “NOCHG” will appear
- CLOCK (+ -) This is used to set the time of day on the display.
- Depress the + button to move the clock forward
- Depress the - button to move the clock backward
- When in PROG Mode, these are used to step through values for setting superheat etc.
- COOLING: Depressing this button will start the system in the cooling cycle immediately (The 4 minutes “Hold Off” is bypassed). This button will illuminate to indicate that the Cooling function is “ON”. System operation will be as described under REFRIGERATION MODE in the Beacon II installation manual.

Pressing the COOLING button while the system is cooling, and the button illuminated, will pumpdown the system and turn it off.

- DEFROST: Depressing this button will force the system into defrost immediately (The “Hold Off/Hold On” times are bypassed). This button will illuminate to indicate that the Defrost function is “ON”. When in Defrost, pressing this button twice will end defrost.

Programming Smart Controller

PROGRAMMING SMART CONTROLLER

To make a change, press the PROGRAM REVIEW button until the setpoint item that needs to be changed is displayed. The SETPOINT Slide-bar is then used to change to the desired new setting. When the new desired setting is displayed, press the “ENTER” button. The new setting is now programmed into the Smart Controller memory.

Press the PROGRAM REVIEW button and follow the steps below (to back up one step during programming, while pressing the “MONITOR” button, press the “PROGRAM REVIEW” button):

- *DEF TYP* – ELE or AIR: Select for Electric Defrost or Air Defrost then press “ENTER”. This selection will automatically set the defaults for Air and Electric Defrost. Important: This will set the refrigerant type to R404A for Air and R404A for Electric. You must change to the refrigerant you are using in your application if these are incorrect.
- *REF TYP* – Selection for type of refrigerant R-22 (22), R-404A (404), R-507 (507), R-407A (47A), R-407C (47C), R-407F (47F), R448A (48A), R449A (49A).
- *BOX TMP* – Box Temp: -30° F to 70° F. Use “SETPOINT” slide-bar to get desired temperature, then press “ENTER.”
- *SUPRHT* – Superheat: 4 to 20 ° F. Use “SETPOINT” slide-bar to select desired superheat temperature, then press “ENTER.” If multiple evaporators are connected, use the “+” button to set other evaporators on this system.
- *SMT DFT* – Smart Defrost: On/Off. Use “SETPOINT” slide-bar to turn it ON or OFF, then press “ENTER” - (for version 1.2. When Smart Defrost is turned on, 8 defrost periods per day will automatically be programmed. These will be at 12:00 am, 3:00 am, 6:00 am, 9:00 am, 12:00 pm, 3:00 pm, 6:00 pm, and 9:00 pm. Also, the defrost fail safe time will be set to 60 minutes, and the defrost termination temperature will be set to 55°F. The user can change these as needed for the application).
- *DD DFT* – Demand Defrost: On/Off use “SETPOINT” slide-bar to turn it ON or OFF, then press “ENTER”. (The defrost fail-safe time is defaulted to 60 minutes, and the defrost termination temperature will be set to 55° F).
- *DEF ST* – Defrost Start time: Up to 12 settings per day (For dF 1, use the “TIME” slide-bar to select first defrost time, then press “ENTER”. Use + button to scroll to next defrost period, dF 2, use “TIME” slide-bar to select second defrost time and press “ENTER”. Repeat steps for each required defrost period). If defrost times are not programmed the system will use the defaults: Electric Defrost - four per day at 4:00 AM, 10:00 PM, 4:00 PM, 10:00 AM. Air Defrost - two per day at 9:00 AM, 9:00 PM.
- *DEF SAF* – Defrost Fail Safe Time: 10 to 200 minutes. When this time has elapsed, the defrost cycle will end, even if the programmed Defrost Termination temperature was not achieved. Use “SETPOINT” slide-bar to select desired time, then press “ENTER”.
- *DEF TMP* – Defrost Termination Temperature: 40 to 100° F. Use “SETPOINT” slide-bar to select desired temperature, then press “ENTER”. If multiple evaporators are connected, use the “+” button to set other evaporators on this system.
- *ALR HI* – Alarm High Temperature. -40 to 90° F. Use “SETPOINT” slide-bar to select desired temperature, then press “ENTER”.
- *ALR LO* – Alarm Low Temperature -40 to 90° F. Use “SETPOINT” slide-bar to select desired temperature, then press “ENTER”.
- *ALR MIN* – Alarm Time, in minutes. Condition must exceed before alarm is indicated: 2 to 120 minutes. Use “SETPOINT” slide-bar to select desired time, then press “ENTER”.
- *F/C* – ° F or ° C. Use “SETPOINT” slide-bar to select then press “ENTER”.
- *12/24H* – Clock: 12H is for standard time. 24H is for international time. Use “SETPOINT” slide-bar to select, then press “ENTER”.
- *FNSTIR* – Evaporator fan stirring: On/Off. Use “SETPOINT” slide-bar to turn it On or Off, then press “ENTER”.
- *TEST* – OFF or ON: Puts all evaporators in TEST mode. Use with Caution. This will cycle each output at 10 second intervals. Use “SETPOINT” slide-bar to select, then press “ENTER”. Return to “OFF” and then press “ENTER” to end the test.
- *SERVIC* – ON or OFF: When placed in the ON mode this will pump the system down and shut it off. The system will not restart until SERVIC is placed back in the OFF mode.

When multiple evaporators are connected as master/slave, depressing the + or - button will display information specific to each evaporator. Units in a master/slave connection are numbered 1 through 4. The first evaporator connected to the SMART CONTROLLER MULTI-OUT Terminals is Evaporator #1.

Monitoring Smart Controller

MONITORING SMART CONTROLLER

The monitoring function can be used to monitor live system data. The information displayed, such as super-heat, is the actual superheat of the system as it is changing.

Press the MONITOR button and follow the steps below (to back up one step during monitoring, while pressing the “PROGRAM REVIEW” button, press the “MONITOR” button):

- *SUPRHT* – Superheat (use + button to check superheat of other evaporators, if Master/slave)
- *EXVSET* – Expansion valve step setting (Stepper Motor setting 0 to 255 steps: use + button to check other evaporators if Master/slave)
- *SUCTMP* – Evaporator Suction temperature (Measured by the Suction Sensor)
- *SSVTMP* – Saturated Suction temperature at the Evaporator (Determined by Suction Transducer)
- *SUCPRE* – Evaporator Suction Pressure (Measured by Suction Transducer)
- *ODTMP* – Actual outdoor ambient temperature (Measured at the Condensing Unit)
- *DEFTMP* – Evaporator coil temperature (Used to terminate defrost)
- *DEFTIM* – Defrost Time: Length of last defrost
- *EMPCYC* – Comp Cycles:
No of Compressor Cycles since 12:00 midnight
- *EMPRUN* – Comp run time (Measured since 12:00 midnight)
- *SPRTMP* – Spare sensor temperature input
- *VERSION* – Software Version: For each Beacon II Controller (use “+” button to check other evaporators, if Master/slave)
- *VERSION* – Software Version: for Smart Controller

When multiple evaporators are connected as master/slave depressing the + or - button will display information specific to each evaporator. Units in a master/slave connection are numbered 1 through 4.

The first evaporator connected to the SMART CONTROLLER MULTI-OUT Terminals is Evaporator #1 and must be a “master” board.

Locking Beacon II Smart Controller

LOCKING BEACON II SMART CONTROLLER

BEACON II SMART CONTROLLER is lockable to prevent programmed settings to be changed by unauthorized personnel. When the Controller is Locked, all the Buttons, except for the MONITOR, CLEAR, and PROG REVIEW buttons, are disabled.

To LOCK the settings, do the following:

- Press “PROG REVIEW” button.
- Press and hold “MONITOR” button
- While holding “MONITOR” button, Press “ENTER” button.
- The LCD will display LOCK

This will prevent unauthorized persons from changing any settings.

To UNLOCK the Controller, repeat these steps.

ERROR CODES

- BXSEN - Room temperature sensor shorted, open or not installed
- DFSEN - Defrost temperature sensor shorted, open or not installed
- STSEN - Suction Temperature sensor shorted, open or not installed
- SPSEN - Suction pressure transducer shorted, open or not installed
- ODSEN - Outdoor temperature sensor shorted
- SUPLO - Superheat too low
- SHTDN - Compressor shutdown (High or low refrigerant pressure or low oil pressure)

The error code will flash alternately with the normal display information. When the error condition is corrected, the error code will no longer be displayed and only the normal information will be displayed.

WIRING ERROR

If the Beacon II Smart Controller LCD displays +COMM+ , this indicates that there is an error in the communication wiring or that the wiring is broken, disconnected, shorted, or there is power loss to one of the boards.

The communication wiring is the MULTI IN and MULTI OUT connections. Check to make sure the OUT is connected to IN. Never connect OUT to OUT or IN to IN.

Alarm Codes

Alarm Codes

- *BOXHI : Box temperature too high
- *BOXLO : Box temperature too low
- *STRUP :System Start-up failure
Compressor pumps down and tries to restart after 4 minutes.
- *INFLT : Input fault (Box Temp.,
Suction Temp., Pressure Transducer
open or not installed)
- Power failure

When an ALARM condition occurs, the BEACON II SMART CONTROLLER will display “CALL FOR SERVICE”, the ALARM code, the System Number, and Unit Number, and will sound an internal buzzer.

The alarm code will flash alternately with the normal display information. When the alarm condition is corrected, the alarm code will no longer be displayed and only the normal information will be displayed.

The system will pumpdown and cycle off and will not restart until the fault is cleared for the following conditions:

- Suction sensor shorted, open or not installed
- Room temperature sensor shorted, open or not installed
- Pressure Transducer open or not installed

The system will pumpdown, cycle off and try to restart for three consecutive times. Each try will be after the 4 minutes “Hold Off” period, for the following fault conditions.

- Oil pressure
- High pressure or low pressure cutout

After the fourth try, the Alarm contacts will be closed and an alarm message displayed on the LCD screen. To clear this condition, the system should be cycled through the “Service” mode after correction is complete.

On Multiple systems the Alarm contacts on each of the Master Evaporator will announce Alarms for that system.

ALARM BUZZER

The ALARM buzzer will sound when an Alarm condition occurs. This buzzer will turn off when the Alarm condition is cleared. The buzzer can also be silenced at any time by pressing the “CLEAR” button.

Smart Defrost

The Beacon II Smart Controller continuously monitors the system performance to determine the need for defrost. It uses a variety of data such as the outdoor ambient and box temperature in its decision making process. A defrost cycle will only be triggered at a programmed defrost time if the system determines a defrost is necessary. Defrost times will NOT automatically trigger a defrost cycle, unless the needs of the system call for one.

Activating Smart Defrost:

You must program multiple defrost times into the Smart Controller to provide flexibility for the system to defrost the coil properly. Smart Defrost will only allow the system to defrost at a programmed defrost time. The system will not defrost in between programmed defrost times. Hence, we recommend that a minimum of 8 defrost periods be programmed when Smart Defrost is turned on. The system will not defrost eight times per day but with this many defrost periods it will have better options to keep the coil clear.

To activate Smart Defrost, press the “PROG REVIEW” button until “SMTDFT” is displayed.

Move the “SETPOINT” slide-bar to “ON” then press “ENTER”. Press “CLEAR” to return to the main screen.

For version 1.2., when Smart Defrost is turned on, 8 defrost periods per day will automatically be programmed. These will be at 12:00 am, 3:00 am, 6:00 am, 9:00 am, 12:00 pm, 3:00 pm, 6:00 pm, and 9:00 pm. Also, the defrost fail safe time will be set to 60 minutes, and the defrost termination temperature will be set to 55°F. The user can change these as needed for the application.

Deactivating Smart Defrost:

To turn Smart Defrost off move the “SETPOINT” slide-bar to “OFF” then press “ENTER”. Press “CLEAR” to return to the main screen.

Grounding

Grounding

The earth/chassis ground connections on the new Beacon II and Smart Controller are used for common-mode noise filtering and should be connected to a good chassis ground or earth ground for best noise immunity.

- *Beacon II Board*

- All four corner brass spacers on the Beacon II board should have sheet-metal screws and they should all be screwed in.

- *Smart Controller*

- Run a 20 AWG or larger wire from TB11 of the Smart Control SUB-BASE to ground (the sub-base terminal block connectors are numbered from TB1 on the left to TB13 on the right).

Operational Checkout

After the system has been charged and has operated for at least 2 hours at normal operating conditions without any indication of malfunction, it should be allowed to operate overnight on automatic controls. A thorough recheck of the entire system operation should be made as follows:

- (a) Check compressor discharge and suction pressures. If not within system design limits, determine why and take corrective action.
- (b) Check liquid line sight glass and expansion valve operation. If there are indications that more refrigerant is required, leak test all connections and system components and repair any leaks before adding refrigerant.
- (c) Using suitable instruments, carefully check line voltage and amperage at the compressor terminals. Voltage must be within 10% of that indicated on the condensing unit nameplate. If high or low voltage is indicated, notify the power company. If amperage draw is excessive, immediately determine the cause and take corrective action. On 3 phase motor compressors, check to see that a balanced load is drawn by each phase.
- (d) The maximum approved settings for high pressure controls on Bohn/Heatcraft air cooled condensing equipment is 400 psig. On air cooled systems, check as follows:
 - Disconnect the fan motors or block the condenser inlet air.
 - Watch high pressure gauge for cutout point.
 - Recheck all safety & operating controls for proper operation and adjust if necessary.
- (e) Check head pressure controls for pressure setting.
- (f) Check crankcase heater operation if used.
- (g) Install instruction card and control system diagram for use of building manager or owner.
- (d) Check high and low pressure controls, pressure regulating valves, oil pressure safety controls, and all other safety controls and adjust them, if necessary.
- (e) On freezers only, check the low pressure switch setting. It must be set to 0 PSIG cut out, 10 PSIG cut in, to allow start and operation, especially in cold ambients.
- (f) Liquid line should always be insulated.
- (g) Wiring diagrams, instruction bulletins, etc. attached to the condensing units should be read and filed for future reference.
- (h) All fan motors on air cooled condensers, evaporators, etc. should be checked for proper rotation. Fan motor mounts should be carefully checked for tightness and proper alignment.
- (i) Observe system pressures during charging and initial operation. Do not add oil while the system is short of refrigerant unless oil level is dangerously low.
- (j) Continue charging until system has sufficient refrigerant for proper operation. Do not overcharge. Remember that bubbles in a sight glass may be caused by a restriction as well as a shortage of refrigerant.
- (k) Do not leave unit unattended until the system has reached normal operating conditions and the oil charge has been properly adjusted to maintain the oil level at the center of the sight glass.
- (l) At initial start-up, the system may cycle off at 2 minutes and display a low superheat error, then restart itself. This cycle may be repeated a few times. Do not shut the system off. Let the system run, as it may take a few cycles for the electric expansion valve to attain the correct setting for the desired superheat.

Check-Out & Start-Up

After the installation has been completed, the following points should be covered before the system is placed in operation:

- (a) Check all electrical and refrigerant connections. Be sure they are all correct and tight.
- (b) Check voltage taps on transformer. The transformer is shipped wired to 240 voltage tap/connection. If your supply voltage is 208 volt systems, change to 208 voltage tap.
- (c) Check setting of time delay relay for low pressure switch in condensing unit. It should be set at one minute (the second marker).

CAUTION: Extreme care must be taken in starting compressors for the first time after system charging. At this time, all of the oil and most of the refrigerant might be in the compressor creating a condition which could cause compressor damage due to slugging. Activating the crankcase heater for 24 hours prior to start-up is recommended. If no crankcase heater is present, then directing a 500 watt heat lamp or other safe heat source on the lower shell of the compressor for approximately thirty minutes will be beneficial in eliminating this condition which might never reoccur.

Preventive Maintenance

Routine preventive maintenance of any mechanical equipment is critical to its long term reliability. During even normal operation all equipment will experience some deterioration during its lifetime caused by wear and environmental influences. For that reason, regularly scheduled maintenance of your refrigeration equipment is required in order to keep it operating to its maximum efficiency while avoiding potentially costly repairs of a premature failure due to equipment neglect. The following is Bohn/Heatcraft's minimum recommendations

for regularly scheduled preventive maintenance of your McDonald's refrigeration system. Qualified and licensed refrigeration companies only should perform all preventive and corrective maintenance on refrigeration equipment. While we cannot guarantee that close adherence to these recommendations will eliminate all equipment problems, it will greatly reduce the potential for mechanical and electrical failures thus providing increased reliability.

Preventive Maintenance

CONDENSING UNIT

	QUARTERLY	SEMI-ANNUALLY	DATE	DATE	DATE	DATE
Visually inspect unit	4	4				
1 Look for signs of oil stains on interconnection piping and condenser coil. Pay close attention to areas around solder joints, building penetrations and pipe clamps. Check any suspect areas with an electronic leak detector.	4	4				
2 Check condition of moisture indicator in the sight glass of all systems. Look for indication of moisture or flash gas.	4	4				
3 Check condition of condenser. Look for accumulation of dirt and debris. Clean as required.	4	4				
4 Check for unusual noise or vibration. Take corrective action as required.	4	4				
5 Inspect wiring for signs of wear or discoloration	4	4				
Clean condenser coil and blades		4				
1 Periodic cleaning can be accomplished by using a brush, pressurized water and a commercially available foam coil cleaner. If foam cleaner is used, it should not be an acid based cleaner. Follow label directions for appropriate use.		4				
2 Rinse until no residue remains		4				
Check operation of condenser fans		4				
1 Check that each fan rotates freely and quietly. Replace any fan motor that does not rotate smoothly or makes excessive noise.		4				
2 Check all fan blade set screws and tighten as required		4				
3 Replace blades as required.		4				
4 Verify that all motors are mounted securely		4				
Inspect electrical wiring and components		4				
1 Verify that all electrical and ground connections are secure, tighten as required.		4				
2 Check condition of compressor, defrost heater and condenser fan contactors. Look for discoloration and pitting. Replace as required		4				
3 Check operation and calibration of all timers, relays pressure controls and safety controls		4				
4 Clean electrical cabinet. Look for signs of moisture, dirt, debris, insects and wildlife. Take corrective action as required		4				
5 Verify operation of crankcase heaters by measuring amp draw		4				
Check refrigeration cycle for all systems		4				
1 Check suction and discharge temperatures & pressures. If abnormal take appropriate action		4				
2 Check operation of liquid injection on freezer system		4				
3 Check pressure drop across all filters and driers. Replace as required.		4				
4 Verify that superheat at the compressor conforms to specification. (30F to 45F)		4				
Inspect suction accumulators		4				
1 Inspect all accumulators for signs of leaks and corrosion.		4				
2 Pay close attention to all copper to steel brazed connections		4				
3 Wire brush all corroded areas and peeling paint.		4				
4 Apply an anticorrosion primer and paint as required.		4				
5 Re-attach insulation and replace any damaged sections		4				

Preventive Maintenance

UNIT COOLERS

	QUARTERLY	SEMI-ANNUALLY	DATE	DATE	DATE
Visually inspect unit	4	4			
1 Look for signs of corrosion on fins, cabinet, copper tubing and solder joints	4	4			
2 Look for excessive or unusual vibration for fan blades or sheet metal panels when in operation. Identify fan cells, causing vibration and check motor and blade carefully.	4	4			
3 Look for oil stains on headers, return bends, and coil fins. Check any suspect areas with an electronic leak detector.	4	4			
4 Check drain pan to insure that drain is clear of debris, obstructions or ice build-up and is free draining.	4	4			
5 Insure that there is sufficient clearance free of obstructions around unit coolers to allow proper airflow through coils	4	4			
6 Verify Box setpoint temperature is being met	4	4			
Clean Evaporator coil and blades					
Periodic cleaning can be accomplished by using a brush, pressurized water or a commercially available Evaporator Coil Cleaner. Never use an acid based cleaner. Always follow label directions for appropriate use. Be sure the product you use is approved for use in food service applications.		4			
2 Flush and rinse coil until no residue remains.		4			
3 Pay close attention to drain pan, drain line and trap.					
Check the operation of all fans and ensure airflow is unobstructed		4			
1 Check that each fan rotates freely and quietly. Replace any fan motor that does not rotate smoothly or makes an unusual noise.		4			
2 Check all fan set screws and tighten if needed.		4			
3 Check all fan blades for signs of stress or wear. Replace any blades that are worn, cracked or bent.		4			
4 Verify that all fan motors are securely fastened.		4			
Inspect electrical wiring and components		4			
1 Visually inspect all wiring for wear, kinks, bare areas and discoloration. Replace any wiring found to be damaged		4			
2 Verify that all electrical and ground connections are secure, tighten if necessary.		4			
3 Check operation/calibration of all fan cycle and defrost controls when used.		4			
4 Look for abnormal accumulation of ice patterns and adjust defrost cycles accordingly		4			
5 Compare actual defrost heater amp draw against unit data plate. (freezer only)		4			
6 Visually inspect heaters to ensure even surface contact with the coil. If heaters have creeped decrease defrost termination temperature and be sure you have even coil frost patterns. (freezer only)		4			
7 Check low voltage wiring at Beacon board for broken wires		4			
8 Check voltage at Beacon board. Should be between 18 to 30 Volts		4			
Check Beacon sensors		4			
1 Press MONITOR button to display sensor reading for Box Temp., Suction Temp. and Defrost Temp.		4			
2 Use an accurate Thermometer to measure temperatures at the same locations as the sensors.		4			
3 LED readings should match measured values, within 3 °F at same locations as sensors.		4			
Check Beacon Pressure Transducer		4			
1 Press MONITOR button to display Suction Pressure reading at the Evaporator		4			
2 Use an accurate Gauge Set to measure Evaporator Pressure.		4			
3 Measured suction pressure should match LED displayed value within 2 Psig.		4			
Check Drain Line Heater		4			
1 Check heater amps		4			
2 Check that heater is wrapped around entire length of drain line inside the walk-in freezer		4			
Refrigeration Cycle		4			
1 Check unit cooler superheat and compare reading for your specific application		4			
2 Visually inspect coil for even refrigerant distribution		4			

Diagnostics

Beacon II Troubleshooting Guide

PROBLEM	Step	ACTION ITEM	IF OK	IF NOT OK
LED is not lit.	1. 2. 3. 4. 5.	Check Primary Power Supply Disconnect Check Voltage to Evaporator Transformer Check Transformer Secondary Output Volts Check Voltage at Control Board (24V and C) Replace Control Board	Go to next step	1. Check fuses and circuit breakers 2. Check field wiring for breaks 3. Replace if necessary 4. Check factory wiring and connections
LED shows Coo, but compressor will not run.	1. 2. 3. 4.	Check Compressor internal overloads Check Control Power to Condensing Unit (24 Volts across "COMP" and "C" at board) Check Compressor Contactor Coil Voltage Check Compressor Contactor "pulled in"	Go to next step	1. Wait for reset 2. Check transformer voltage (secondary and primary) and wiring of 208V power taps. 3. Check internal condensing unit wiring 4. Replace as needed
ERROR CODES: E1 Room Sensor E2 Defrost Sensor E3 Suction Sensor E4 Suction Transducer E5 Outdoor Sensor		Check Sensor and Board Connection Check Sensor and Board Connection Check Sensor and Board Connection Check Transducer and Board Connection Check Sensor, wiring and Board Connection		Replace as needed Replace as needed Replace as needed Replace as needed Replace or remove
E6 Low Superheat During Cooling (0°F for 2 minutes)	1. 2. 3. 4. 5. 6. 7.	Check Refrigerant Type Check coil for ice Check Control Board step position from board LED Check Electric Expansion Valve Closure Compressor Not Operating Check Suction Temperature Sensor Check Suction Pressure Transducer	Go to next step	1. Compare board setpoint and refrigerant 2. Defrost coil and check defrost cycle settings/setpoints, defrost sensor and heater amps. 3. Replace board if EEV steps not at 2. 4. Pumpdown system. See if LPS opens or if it times out (EEV is bad or LPS is set incorrectly, if times out) – See Pumpdown. 5. Check overloads and contactor. 6. Compare board sensor reading against actual suction line temperature. 7. Compare pressure reading against gauges.

Diagnostics

Beacon II Troubleshooting Guide (continued)

PROBLEM	Step	ACTION ITEM	IF OK	IF NOT OK
E7 Compressor Shutdown	1.	Check wiring connection to the board	Go to next step	<ul style="list-style-type: none"> • Correct field wiring to the board
	2.	Low Pressure Safety (LPS) Tripped: <ul style="list-style-type: none"> • Check for correct refrigerant type • Check refrigerant charge • Check LPS setting • Check LPS wiring • Check EEV operation (stuck?) • Check coil for icing • Check for correct superheat reading • Check for correct nozzle selection • Check for clogged EEV inlet screen • Check line sizing • Check LPS time delay relay setting • Check operation of LPS 		<ul style="list-style-type: none"> • Change setpoint to match refrigerant • Add more refrigerant to proper charge • Correct LPS setting • Correct LSP wiring • Clean or replace EEV • Defrost coil (see E6, step 2) • Check/replace sensor or transducer • Replace distributor nozzle • Replace EEV • Correct line sizing • Reset to 1 minute • Replace Low Pressure Safety Switch
	3.	High Pressure Safety (HPS) Tripped: <ul style="list-style-type: none"> • Check for system overcharge • Check for non-condensables • Check condenser fan motor and blade • Check for dirty condenser coil • Check head pressure controls • Check fan cycling controls • Check liquid line sizing • Check for liquid line restrictions • Check operation of HPS 		<ul style="list-style-type: none"> • Reclaim/recover excess charge • Remove all non-condensables • Repair or replace motor and/or blade • Clean condenser coil • Adjust or replace faulty controls • Adjust or replace faulty controls • Correct line sizing • Repair line or remove restrictions • Replace HPS if necessary
	4.	Oil Pressure Safety (OPS) Tripped: <ul style="list-style-type: none"> • Check oil level in compressor • Check oil sump screen pickup • Check oil pump pressure • Check for proper piping practices • Check for low superheat (see E6) • Check operation of auxiliary relay (R6) • Check OPS sensor • Check operation of OPS 		<ul style="list-style-type: none"> • Add oil to crankcase to minimum level • Clean or replace pickup screen • Replace compressor oil pump • Correct piping to minimize oil logging • Correct per steps in E6 • Replace auxiliary relay • Replace faulty OPS sensor • Replace faulty OPS
	5.	Compressor Module Tripped (when supplied): <ul style="list-style-type: none"> • Check module • Check superheat at compressor inlet • Check compressor for overheating • Check suction pressure (too low?) 		<ul style="list-style-type: none"> • Replace faulty module • Reduce superheat (TXV adjust, etc.) • Correct overheating problem • Consider crankcase pressure regulator or other measures
	6.	Phase Loss Monitor (PLM) Tripped: <ul style="list-style-type: none"> • Check presence of all phase legs • Check power supply • Check operation of PLM 		<ul style="list-style-type: none"> • Correct power phase problem • Correct power supply problems • Replace faulty PLM
	7.	Demand Cooling (when supplied): <ul style="list-style-type: none"> • Check auxiliary relay • Check demand cooling device 		<ul style="list-style-type: none"> • Replace auxiliary relay • Replace faulty demand cooling device
	8.	Check compressor relay on board		<ul style="list-style-type: none"> • Replace board if relay is faulty

Diagnostics

Beacon II Troubleshooting Guide (continued)

PROBLEM	Step	ACTION ITEM	IF OK	IF NOT OK
E9 Multi-out to Multi-in communication wiring (only shows after initial successful connection)	1.	Check for 24 volts power to the board	Go to next step	1. If no voltage, see "LED is not lit" above for low voltage, see "88888 LED display"
	2.	Check for crossed communication wiring (multi-out not wired to multi-in terminals)		
	3.	Check for broken communication wiring		

Break in the designated lines will cause errors as follows:

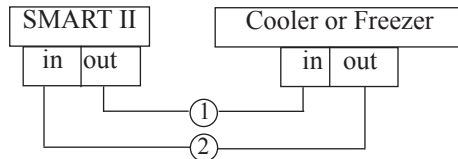

[With SMART Controller II]

Line #	SMART	Cooler or Freezer
1	+COMM+	E9
2	+COMM+	no error

PROBLEM	Step	ACTION ITEM	IF OK	IF NOT OK
88888 LED display (power is below 18V and appears at initial power)	1. 2. 3. 4. 5.	Check grounding of board Check Voltage to Evaporator Transformer Check Transformer Secondary Output Volts Check Voltage at Control Board (24 and C) Check Voltage at SMART Controller II	Go to next step	1. Check field wiring for breaks or shorts 2. Replace if necessary 3. Check factory wiring and connections 4. Check field wiring from board
LED displays dLy then oFF with no displayed errors	1. 2. 3. 4.	Check grounding of board Check for low voltage Check for short in field wiring from "comp" on board to condensing unit terminal connection Replace defective contactor (holding coil)	Go to next step.	1. Check all steps for "88888 LED display" Voltage could drop off too fast to show. 2. Check internal factory wiring to compressor contactor.

Diagnostics

Beacon II Troubleshooting Guide (continued)

PROBLEM	Step	ACTION ITEM	IF OK	IF NOT OK
Cannot get to box temperature	1.	Check system operation: Is it running?	Go to next step	1. Check power to condensing unit Check position of Service Mode switches Check compressor overloads and contactor
	2.	Check system charge		2. Add or remove refrigerant to proper charge
	3.	Check for proper operating superheat		3. Check EEV operation Check control board EEV signal Check suction sensor and transducer
	4.	Check for high superheat and EEV wide open		4. Check EEV inlet screen and restrictions Check liquid line sizing Check head pressure controls
	5.	Check Low Pressure Safety Switch		5. Check everything for E7 LPS above
	6.	Compare equipment capacity with requirements		6. Add or replace with more/larger equipment
	7.	Check box temperature setpoint		7. Correct setpoint to proper value
	8.	Check compressor performance		8. Check compressor application limitations Check integrity of compressor operation (impaired, worn or damaged components)
	9.	Check condenser coil for dirt/debris		9. Clean condenser coil
	10.	Check condenser for non-condensables		10. Remove all non-condensables
	11.	Check condenser fan operation		11. Replace/repair fan blade, motor, cycling switch or make corrective adjustments.
	12.	Check for correct refrigerant type		12. Compare board setpoint and refrigerant
	13.	Check for iced evaporator coil		13. Defrost coil and check defrost cycle (see E2) settings/setpoints and defrost sensor
	14.	Check defrost parameters		14. Correct defrost setpoints in program (frequency and termination of defrosts)
	15.	Check superheat setpoint (too high?)		15. Correct setpoint for more cooling surface
	16.	Check display values (°F or °C)		16. Correct setpoint for proper display values
Service Mode (SEr is displayed)	Placing system into SERVICE MODE (BOARDS ONLY)		Terminating SERVICE MODE (BOARDS ONLY)	
	1.	Use Remote Service Switch in condensing unit	1. Must terminate using same switch	
2.	Pressing "Force Service" button board* twice	2. Press "Clear" button on board		
3.	Connection between "Ser" and "C" on board* (all are wired in parallel; all will activate mode) *ONLY Master board on multiple evaporator systems	3. Open connection between "Ser" and "C" (Note: If multiple switches were placed in Service Mode, <u>all</u> must be "open" to terminate the mode.)		
(with Beacon II Smart Controller)		(with Beacon II Smart Controller)		
1.	Use Remote Service Switch in condensing unit	1. Must terminate using same switch		
2.	Connection between "Ser" and "C" on board*	2. Open connection between "Ser" and "C"		
3.	From program menu of Beacon II Smart Controller, Change SERVICE setpoint to "On". [all are wired in parallel; any/all will activate mode.] *ONLY Master board on multiple evaporator systems	3. From program menu of Beacon II Smart Controller, Change SERVICE setpoint to "Off" [Note: If multiple switches were placed in Service Mode, <u>all</u> must be "open" to terminate the mode.]		

Parts

Table 7. Condensing Unit Parts List

PART DESCRIPTION	CONDENSING UNITS	
	MAC7X	MAC8X
Compressor - Freezer	ZF13K4E	ZF15K4E
Compressor - Cooler	ZS13KAE	ZS13KAE
Disconnect Fuses	22510112	22510113
Start Relay - Cooler	N/A	
Start Capacitor - Cooler	N/A	
Run Capacitor - Cooler	70757856	
Compressor Contactor - Cooler	2254304	
Compressor Contactor - Freezer	2255845	
Condenser Fan Motor	25399101	
Condenser Fan Blade	22999901	
Fan Guard	23104401	
Head Pressure Valve:		
Cooler	29317401	
Freezer	29317304	29317304
High Pressure Control	28903201	
Low Pressure Control - Freezer	2891402	
Low Pressure Control - Cooler	2890099	
Low Pressure Time Delay	22536801	
Crankcase Htr - Freezer	24701301	
Fan Cycling Thermostat	2890019	
Ambient Temperature Sensor*	88904902	
Evaporator Fuses - Freezer	22510002	
Evaporator Fuses - Cooler	22510001	
Fan Relay (R3, R4 - 240v)	22505201	
Fan Relay (R1, R2 - 24v)	22521901	
Terminal Block	2251423	

Table 8. Evaporator Parts List

PART DESCRIPTION	PART NUMBER	EVAPORATORS
Fan Motor	25317701	ALL
Fan Blade	5140C	ALL
Fan Guard	37000701	ALL
Defrost Heater	24752002	LET090BEB2N6MK
	24752003	LET120BEB2N6MK
	24752004	LET160BEB2N6MK
	24752004	LET180BEB2N6MK
Defrost Pan Heater	24752402	LET090BEB2N6MK
	24752403	LET120BEB2N6MK
	24752404	LET160BEB2N6MK
	24752404	LET180BEB2N6MK
Electric Expansion Valve	29326201	ADT070BEB2N6MK
	29326201	LET090BEB2N6MK
	29326201	ADT052BEB2N6MK
	29326201	LET120BEB2N6MK
	29326201	LET160BEB2N6MK
	29326201	ADT104BEB2N6MK
	29326201	LET180BEB2N6MK
Expansion Valve Harness	22592101	ALL
Beacon II Control Board	28910103	ALL
Temperature Sensor Kit*	89904902	ALL
Transformer (240/24 - 40 VA)	22529602	ALL
Pressure Transducer	28911201	ALL
Pressure Transducer Harness	22515101	ALL

*Only the sensor with white leads is shipped as a Service Replacement Part.

Beacon II Smart Controller

Table 9. Beacon II Smart Controller Parts List

PART DESCRIPTION	PART NUMBER
Beacon II Smart Controller	89704302

Table 10. Beacon II Operational Limits

OPERATIONAL LIMITS	
Voltage	22 VAC to 30 VAC
Controlling Box Temp. Range	-30°F to 70°F
Box Temp. Dead-Band	+/-1°F
Cold Ambient Limits	Start and operate to -20°F

Startup Checklist

Date of Start-up _____

Store Address _____

CONDENSING UNIT

MODEL # _____

SERIAL # _____

COOLER UNIT

MODEL # _____

SERIAL # _____

FREEZER UNIT

MODEL # _____

SERIAL # _____

ELECTRICAL

- Check primary supply voltage.
If 208 V, change transformer wiring in the cooler and freezer to the 208 V tap
 YES
- Check compressor amps for COOLER and FREEZER compressors. Should match nameplate.
 YES NO

PIPING

- Is suction line trapped at the cooler?
 YES NO
- Is suction line trapped at the freezer?
 YES NO

DRAIN LINES

- Are drain lines sloped properly?
 YES NO
- Is drain line trapped outside the cooler?
 YES NO
- Is drain line trapped outside the freezer?
 YES NO
- Is heat tape wrapped along entire length of the drain line in the Freezer?
 YES NO
- Is heat tape plugged in and heating the drain line?
 YES NO

INSULATION

- Are liquid lines fully insulated?
 YES NO
- Are suction lines fully insulated?
 YES NO

SETTINGS

- Check Beacon II board settings for the following:
FREEZER
Refrigerant Type R448A
Box Setpoint Temp. -10°F.
Superheat 8°F.
No. of Defrost/Day 4
Defrost End Temp. 65°F.

COOLER

Refrigerant Type R448A
Box Setpoint Temp. 35°F.
Superheat 8°F.
No. of Defrost/Day 2
Defrost End Temp. 50°F.

SYSTEM CHECKS

- Check compressor superheat for the COOLER (Should be between 20°F. & 30°F.)
 YES NO
- Check compressor superheat for the FREEZER (Should be between 20°F. & 30°F.)
 YES NO
- Force unit into a defrost check heater amps. Should match nameplate amps.
 YES NO
- Check LPS time delay relays. Should be set at 1 minute for both the COOLER and FREEZER.
 YES NO
- Check low pressure switch on FREEZER. Should be set at 0 psig Cut-out/10 psig Cut-in.
 YES NO
- Did FREEZER and COOLER cycle off on LPS at set-point temperature?
 YES NO
- Is the sight glass free of bubbles?
 YES NO
- Are the COOLER and FREEZER fans at proper speeds?
 YES NO
- Check system for refrigerant leaks. Are there any leaks on the COOLER, FREEZER, CONDENSING UNIT or INTERCONNECTING PIPING?
 YES NO
- Check system piping for unusual vibration or noise. Is there any unusual vibration or noise on the COOLER, FREEZER, CONDENSING UNIT or INTERCONNECTING PIPING?
 YES NO
- Start the FREEZER only. Does the compressor start and evaporator fans run for this FREEZER?
 YES NO

Startup Checklist

RECORD

OUTDOOR TEMPERATURE _____ °F.

SYSTEM VOLTAGE _____ Volts _____ PH _____ Hz

Cooler compressor amps _____ L1 _____ L2 _____ L3

Freezer compressor amps _____ L1 _____ L2 _____ L3

Cooler discharge pressure _____ PSIG

Freezer discharge pressure _____ PSIG

Cooler suction pressure _____ PSIG

Freezer suction pressure _____ PSIG

Cooler suction temperature _____ °F.

Freezer suction temperature _____ °F.

Cooler refrigerant charge _____ lbs.

Freezer refrigerant charge _____ lbs.

Cooler compressor superheat _____ °F.

Freezer compressor superheat _____ °F.

Cooler evaporator superheat _____ °F.

Freezer evaporator superheat _____ °F.

Cooler discharge temperature _____ °F.

Freezer discharge temperature _____ °F.

Wiring Diagrams

Diagram 1. Low Profile Evaporator Wiring

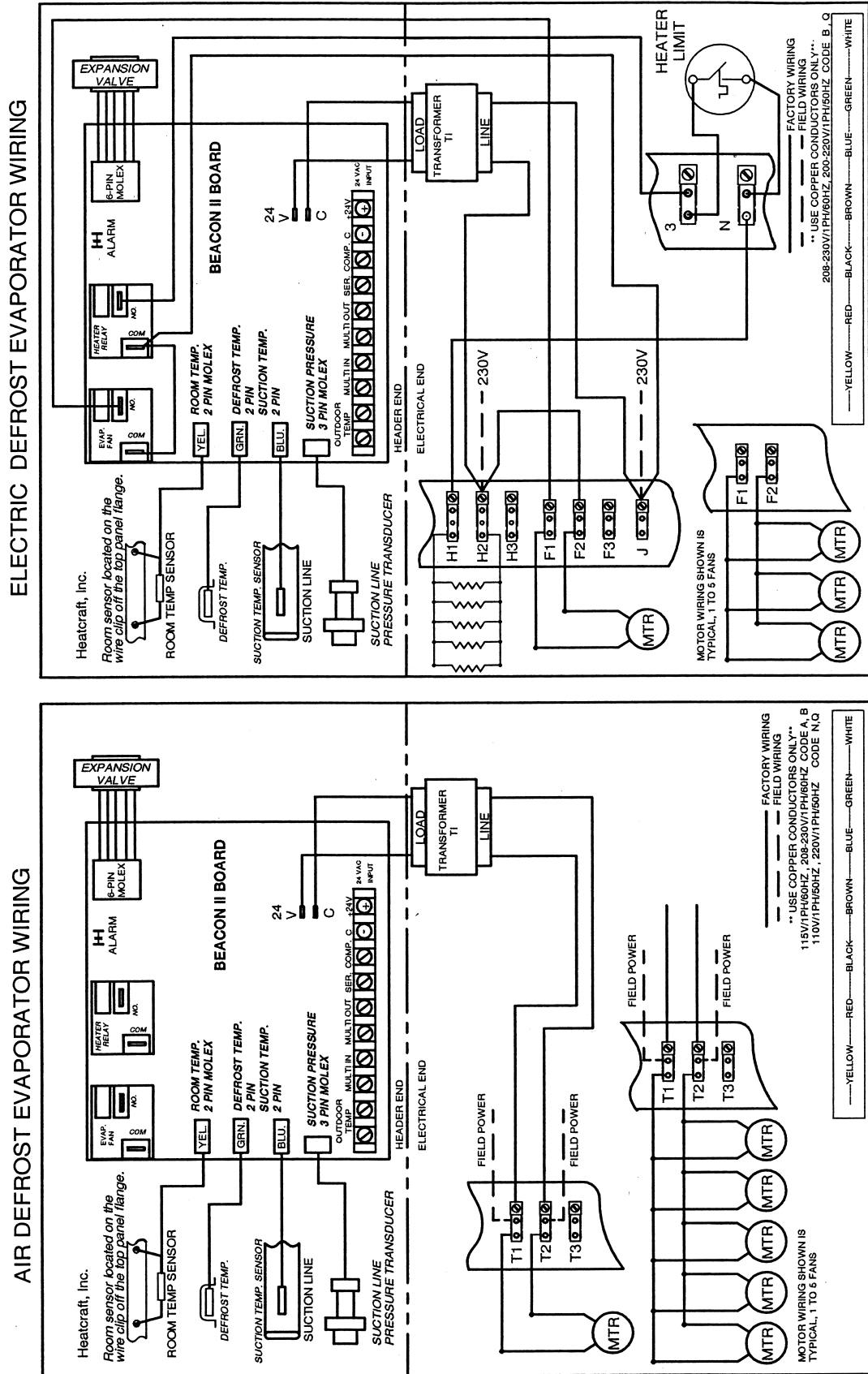

NOTE: THESE ARE TYPICAL EVAPORATOR WIRING DIAGRAMS. CONSULT WIRING DIAGRAM SHIPPED ON UNIT FOR ACTUAL UNIT WIRING.

Wiring Diagrams

Diagram 2. MAC Unit Wiring

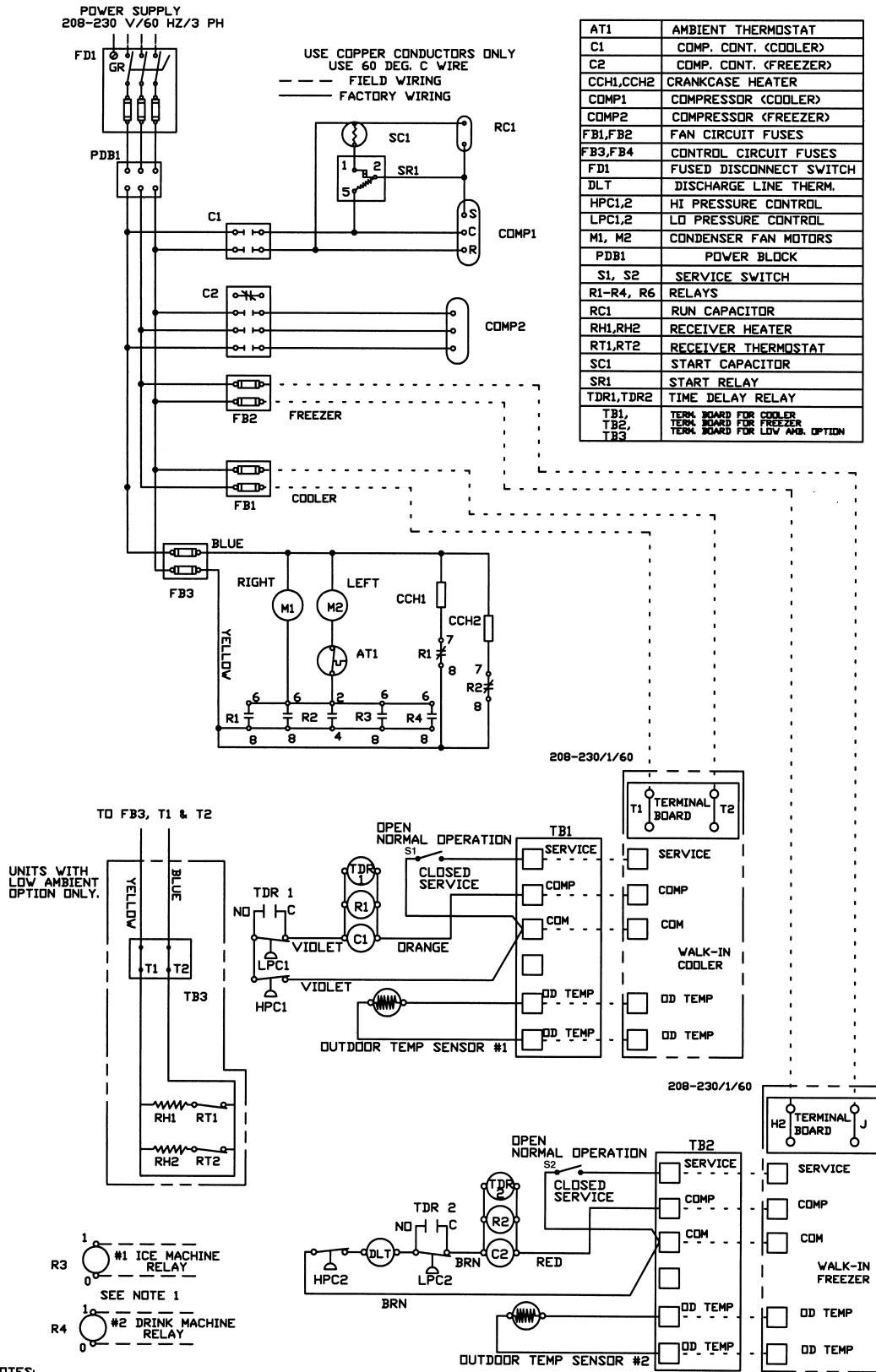

- NOTES:
1. FIELD WIRED FAN RELAYS FOR ICE AND DRINK MACHINES HAVE 208-230 VOLT CONTROL CIRCUITS.
 2. TIME DELAY RELAY SET AT 1 MINUTE (SECOND DASH MARKING)
 3. IF ADJUSTABLE, LPS SET TO 10 PSIG CUT-IN, 10 PSIG DIFF CUT-OUT

Wiring Diagrams

Diagram 3. 24 Volt Connection Wiring with Smart Controller

COOLER

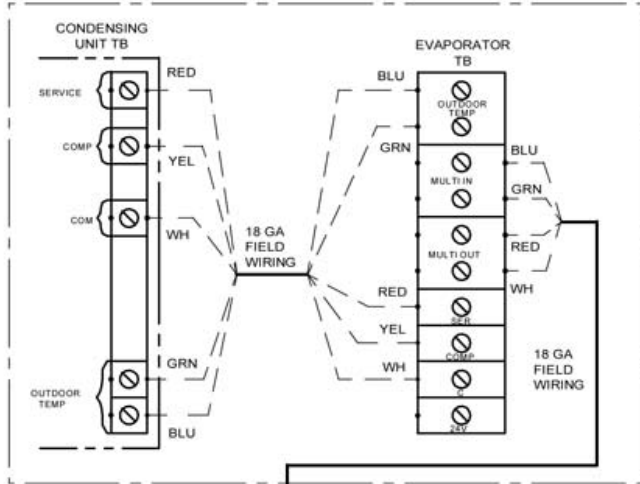

FREEZER

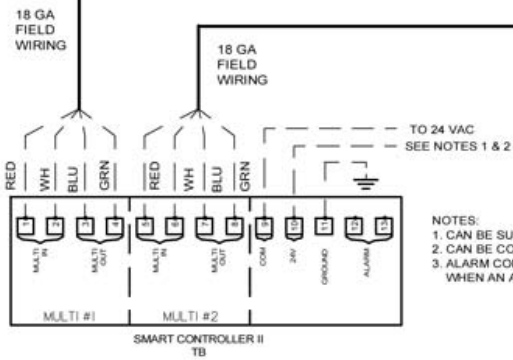
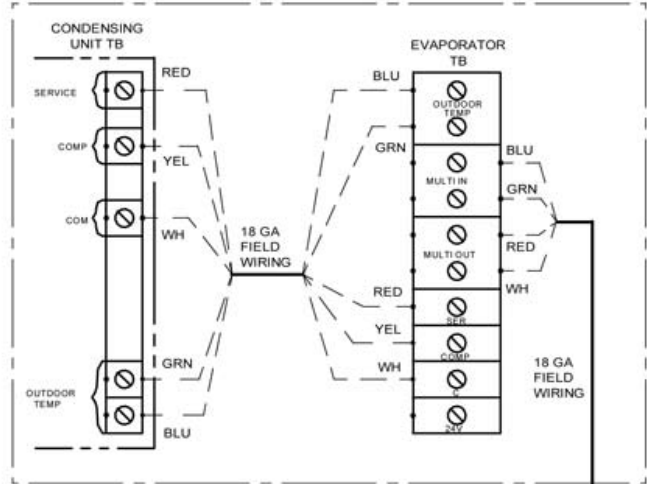

- NOTES:
1. CAN BE SUPPLIED INDEPENDENTLY BY USING A 120/24 VAC POWER SUPPLY (300mA).
 2. CAN BE CONNECTED TO (1) BEACON BOARD AT THE EVAPORATOR (TERMINALS 24V & C).
 3. ALARM CONNECTION GOES TO A DRY CONTACT THAT CLOSSES UPON LOSS OF POWER OR WHEN AN ALARM IS ACTIVATED (24 VAC, 1 AMP CONTACT).

For Warranty Service 24 Hours a Day, 7 Days a Week
Call Toll Free (877) HTCRAFT (877-482-7238)

Warranty Coverage
Standard Parts & Labor - 2 Years
Beacon Parts (TXV, Sensors, Board, Smart Controller) - 3 Years
Compressor Part - 5 Years

Due to ongoing efforts in product improvement, specifications are subject to change without notice.

BOHN

A Brand of Heatcraft Refrigeration Products LLC

2175 West Park Place Blvd. • Stone Mountain, GA 30087

770.465.5600 • Fax: 770.465.5990

www.heatcraftprd.com

